

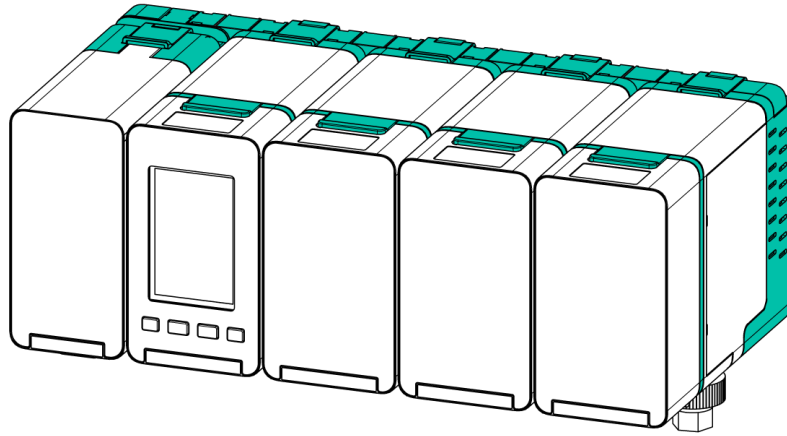

# PS-8 Series Gas Detector

for use in semiconductor manufacturing plant

## Instruction Manual for Communication



Keep this manual for easy reference.

Read and understand this manual carefully before using this product correctly.

This manual describes the standard model. If your unit has end-user-specific options, this manual will be superseded by your delivery specifications.



Instruction Manual No.  
GAE-180-00  
December 2024

**NEW COSMOS ELECTRIC CO., LTD.**

## Related Manuals

The following documents have been prepared to guide your installation and use of this product.

### **PS-8 Series Instruction Manual for Installation, No. GAE-178**

---

This document is intended for your supervisors and service personnel who are concerned with the installation of this product. It also provides the following information to ensure correct installation of the product:

- Safety precautions
- Unit dimensions and components and precautions for unpacking
- Installation precautions

### **PS-8 Series Instruction Manual for Operation, No. GAE-179**

---

This document is intended for your supervisors, operators and service personnel who are concerned with the operation and maintenance of this product. It provides the following information to ensure the safe use of the product:

- Unit dimensions and components and power on/off
- Operation modes and on-screen menus
- Setup procedures
- Maintenance procedure, consumable replacement and troubleshooting

### **PS-8 Series Instruction Manual for Communication (this document), No. GAE-180**

---

This document is intended to provide the communication specifications and procedure to establish communication with external devices.

# Introduction

Thank you for purchasing the New Cosmos PS-8 series extractive type gas detector (“product” or “unit” hereafter).

Prior to use, please read this manual as well as the related manuals and follow the instructions provided for correct use of the product.

Periodic maintenance is essential to maintain the reliability of the product. Periodic maintenance must be performed in the manner described in this document.

Keep this manual in a safe place for easy reference.

This product is a gas detector designed for use in semiconductor manufacturing plants. It monitors semiconductor process gases or flammable gases (e.g., hydrogen) that may be present in a cylinder cabinet, exhaust duct, or workspace within a semiconductor manufacturing plant. The unit displays the measured gas concentrations on its screen and transmits them as an analog signal, contact signal, and/or Ethernet signal to external equipment. If the gas concentration level reaches a preset threshold, the alarm LEDs will start blinking and simultaneously activate the external relay contacts (1st and 2nd gas alarm contacts), providing early detection of a potential gas leak.

The following acts are prohibited without the prior consent of New Cosmos. Please note that the use of this product will be treated as your acceptance of these terms. If you do not agree to these terms, do not use this product, and immediately consult your local sales representative.

- Modification of this product and its related components
- Reverse-engineering of this product and its related components
- Analysis of this product and its related components including disassembly and reverse compilation
- Transfer of this product and its related components to a third party
- Third-party use of this product and its related components for any reason, including lease and licensing

## Notation Rules for Registered Trademarks

\* Modbus® is a registered trademark of Modicon Inc. (AEG Schneider Automation International S.A.S).

- All other company names and product names used in this manual are trademarks or registered trademarks of their respective companies.
- The trademarks or registered trademarks used in this document are not accompanied by a TM or ® symbol.

## Precautions

Unauthorized copying and replication of the contents of this manual, in whole or in part, are strictly prohibited.

The contents of this manual are subject to change without notice.

This manual has been prepared with the utmost care. If any incorrect description comes to your notice, please contact us for correction.

## Symbols Used in this Instruction Manual

### Symbols for Danger Levels

Operators' safety has been put first in designing this product. However, there exist some unavoidable risks due to the system characteristics. In this manual, safety symbols are divided into three categories,

Danger, Warning and Caution, depending on the severity and magnitude of the risks. Carefully read the contents related to the precautions before operation and maintenance work. This manual uses Danger, Warning, Caution and Notice symbols to draw attention to procedures, materials, methods, and processes that require particular attention.

 <b>DANGER</b>
Indicates an imminently hazardous situation that can result in death or serious injury.
 <b>WARNING</b>
Indicates a potentially hazardous situation that may result in death or serious injury.
 <b>CAUTION</b>
Indicates a hazardous situation that may result in minor injury or property damage.
<b>NOTICE</b>
Indicates a hazardous situation that will not result in injury but may cause a product, facility, or related equipment damage or failure.





### Other Signs

This manual uses the following notations in addition to the aforementioned hazard level classifications.

<b>NOTE</b>	Provides supplemental or useful information on product handling.
<b>Ref.</b>	References with related content and common procedures.

### Symbol Marks

This manual uses the following symbol marks to outline the contents of the description.

	Don'ts Indicates a prohibited action.
	Mandatory Indicates an action that must be done.
	Electrical hazard Warns of risk of electric shock under a certain condition.
	Explosive hazard Warns of risk of explosion while handling explosive items.
	Corrosive hazard May cause burn or loss of sight if skin or eye comes into contact.

## Model Variations

This product is divided into the following models according to the sensor unit and functions that meet the customer's specifications.

### Main Unit

Model	Power Supply		Output Signal		Collective Contact Output (AL1, AL2 and Fault)
	PoE	24 VDC	Ethernet	Analog Signal	
PS-8M	✓	✓	✓	✓	✓
PS-8N		✓		✓	✓

### Subunit

Model	Power Supply	Output Signal	Contact Output
PS-8S	None*1	None*2	None*3

\*1: Power is supplied from the main unit.

\*2: If analog signal output is required, an expansion unit with an AO module (sold separately) needs to be added.

\*3: If at least one of the sensor channels generates a gas alarm or fault alarm, a collective gas or fault alarm contact output is generated by the main unit. If a dedicated gas or fault alarm contact output is required for each sensor channel, an expansion unit with a DO module (sold separately, up to two channels per DO module) is required. The collective alarm contacts (AL1, AL2, and Fault) are located in the main unit, not in the subunits.

### Expansion Unit

Model	Module Type	Function	Remarks
PS-8EU*	PS-8EUM-AO	Analog output	Up to four channels can be supported by each AO module.
	PS-8EUM-DO	Contact output dedicated to each individual sensor channel (AL1, AL2, and Fault)	Up to two channels can be supported by each DO module.
	PS-8EUM-AI	Analog input	Up to two channels can be supported by each AI module.

\*4: A maximum of two modules can be installed in one expansion unit.

### Sensor Unit

Model	Sensor Type	Detection Principle
CDS-7	Toxic gas sensor	Electrochemical sensor
CHS-7	Flammable gas sensor	Hot wire semiconductor sensor
COS-7	Oxygen sensor	Galvanic cell sensor

# Quick Index

This page lists parts that may be often referenced.  
Prior to use, please read the precautions in "1 General Precautions".

## Communication Specifications, Connection Specifications

Pages 6 to 9

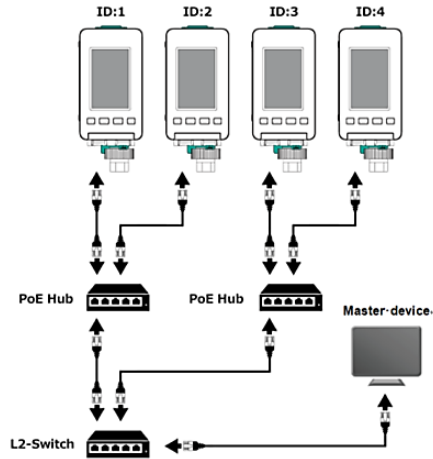

## Communication settings

Pages 10 and 11

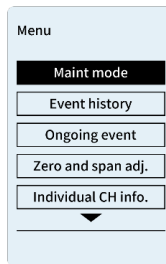

## Register Address Maps

Pages 21 to 38

Register No.	Relative address		Words	Unit	Sensor Ch.	Register item	Access	Type	Data contents
	Dec	hex							
40001	0	0	2	Sensor	1	Status / Fault simulation test status	R	DWord	It reads the status of sensor 1 or the Fault simulation test mode status (in fault simulation test). 0: Fault simulation test OFF 1: Fault simulation test ON bit31: Heartbeat bit30-bit23: Reservation bit22: Maint mode collective flag (Target of collective: bit14-bit11) bit21: Fault collective flag (Target of collective: bit9-bit4) bit20: In monitoring mode (No fault, alarm, maintenance, warm-up, aging, or testing) bit19: Over range bit18: Abnormalities in continued operation bit17: Aging mode bit16: Warm-up bit15: Test mode bit14: Maint mode C2 (When setting by external operation) bit13: Maint mode C1 (When setting by external operation) bit12: Maint mode M2 (When setting by device operation) bit11: Maint mode M1 (When setting by device operation) bit10: Low battery power in wireless child device (For preliminary alarm) bit9: Low battery power in wireless child device bit8: Pyrolyzer failure bit7: Interunit comm. failure bit6: Device failure bit5: Fan failure bit4: Sensor-related collective failure (Target of collective: bit2 to bit1 of failure detail status) bit3: Low flow failure bit2: Preliminary alarm (Zero suppr. on alarm side, over 20.9 suppr.) bit1: Alarm 2 bit0: Alarm 1

# Table of Contents

Related Manuals.....	i
Introduction.....	ii
Notation Rules for Registered Trademarks.....	ii
Precautions.....	ii
Symbols Used in this Instruction Manual.....	ii
Model Variations.....	iv
Quick Index.....	v
1 General Precautions.....	1
1.1 Before Work.....	1
1.2 Safety Precautions.....	1
1.3 Labels Affixed to Product.....	2
1.4 Disposal.....	4
1.5 Service Life.....	4
1.6 Definition of Supervisor/Operator/Service Personnel.....	4
2 System Configuration.....	5
3 Communication Specifications.....	6
3.1 Modbus TCP Communication Specifications.....	6
4 Connection Specifications.....	7
4.1 Communication System Configuration.....	7
4.1.1 Example of Checking the Specifications of the Modbus Master Device (Host Device).....	8
4.2 Wiring.....	9
5 Communication settings.....	10
5.1 Communication Mode Setting.....	10
5.2 Modbus TCP (Ethernet) Setting.....	10
5.2.1 Target Browser.....	10
5.2.2 IP Address Setting.....	10
5.2.3 Network Environment Setting.....	11
5.2.4 Communication check.....	11
6 Communication Protocol.....	12
6.1 Overview of Modbus Communication Protocol.....	12
6.1.1 Message Configuration.....	12
6.1.2 Communication Procedures.....	13
6.2 Function Codes.....	14
6.3 Response of Error Occurs.....	14
6.3.1 Error Codes (Exception Codes).....	15
6.4 Example of Message Communication.....	16
6.4.1 Function Code No. 03 (Holding Register Read) Communication Example.....	16
6.4.2 Function Code No. 06 (Holding Register Write) Communication Example.....	17
6.4.3 Function Code No. 16 (Holding Register Continuous Write) Communication Example.....	18
6.4.4 Error Response Message Communication Example.....	20
6.5 Register Address Maps.....	21
7 Device Status Information.....	39
7.1 Explanation of Operation at Gas Alarm.....	39
7.2 Explanation of Operation at Trouble Alarm.....	40
7.3 Explanation of Test Mode Settings and Operation.....	42
7.4 Explanation of Maintenance Mode Settings and Operation.....	44

8	Before Assuming Malfunction.....	46
9	Glossary .....	47





# 1 General Precautions

## 1.1 Before Work



In order to ensure safe use, please carefully read the precautions in this manual before turning on the product to prevent unexpected accidents. New Cosmos is not liable for any cost incurred or any damage resulting from any usage other than that outlined in this document.



Do not use the product in a manner other than that described in this document. Doing so may impair the electrical/mechanical protection functions of the product.



This chapter “General Precautions” provides a general description of methods of safely using this product as well as safety information and cautions related to this product.



## 1.2 Safety Precautions



Please carefully read the following precautions for correct use.  
 Use this product in accordance with the applicable laws and regulations.  
 Wiring and installation must only be performed by a qualified electrician with sufficient knowledge of wiring/installation procedures in accordance with the applicable technical standards.

 <b>DANGER</b>	
	<ul style="list-style-type: none"> <li>Do not put your face close to the exhaust port of this unit. Doing so may cause the inhalation of oxygen-free air or toxic gases that are harmful to human health.</li> </ul>

 <b>DANGER</b>	
	<ul style="list-style-type: none"> <li>Operation check using actual gas is extremely dangerous and requires a special attention, because flammable gas may have a risk of explosion and toxic gas may be harmful to human health. It must be performed by qualified personnel or a New Cosmos authorized technician.</li> <li>If the liquid leaks from the sensor due to vibration or shock and gets on your hands or clothes, wash them with water immediately. Moreover, if the liquid gets into your eyes or ears, wash them with plenty of water as first aid and seek immediate medical advice.</li> <li>This product is not explosion-proof and must not be installed in a hazardous area.</li> </ul>

 <b>WARNING</b>	
	<ul style="list-style-type: none"> <li>Ground the product to prevent electric shocks.</li> <li>In the event of a gas leak alarm, follow safety procedures in accordance with your company's regulations.</li> <li>This product is heavyweight. Handle it with care not to drop it. Failure to do so may cause injury or property damage such as damaged floor.</li> </ul>

 <b>CAUTION</b>	
	<ul style="list-style-type: none"> <li>Do not use radio wave-emitting devices (e.g., walkie-talkies, cell phones, wireless devices) in the vicinity of the product.</li> <li>Do not disassemble, modify, or alter the structure of the product or its electrical circuits. Doing so may compromise product performance.</li> </ul>

 <b>CAUTION</b>	
	<ul style="list-style-type: none"> <li>Wiring and installation must only be performed by a qualified electrician with sufficient knowledge of wiring/installation procedures, in accordance with the applicable technical standards.</li> <li>New Cosmos is not liable for any cost incurred or any damage resulting from controlling external equipment (e.g., interlock) by using the product's outputs (e.g., analog output, alarm contact output).</li> <li>Only use this product in accordance with the applicable laws and regulations.</li> <li>This product is not drip-proof and should be kept away from water or rain.</li> </ul>

<b>NOTICE</b>	
	<ul style="list-style-type: none"> <li>Do not use organic solvents for cleaning the product. Organic solvents may negatively affect the product's exterior as well as internal components.</li> </ul>

<b>NOTICE</b>	
	<ul style="list-style-type: none"> <li>New Cosmos is not liable for any cost incurred or any damage resulting from a measurement data or information breach.</li> </ul>

### 1.3 Labels Affixed to Product

Danger, Warning and Caution labels are affixed to the areas or surrounding parts that are potentially dangerous and require a special attention. Prior to use, please read the instructions in these labels.

 <b>WARNING</b>	
	<ul style="list-style-type: none"> <li>Do not relocate the labels affixed to the product.</li> </ul>

 <b>WARNING</b>	
	<ul style="list-style-type: none"> <li>If Danger, Warning and Caution labels are missing, damaged or illegible, please contact New Cosmos or its authorized representative for replacement. It is extremely dangerous to leave the labels dirty or obscured.</li> </ul>

Prior to use, please read these labels. Labels that are not specified below are for control by New Cosmos. Operation and maintenance work of the appliance is not affected.

**Labels for Main Unit and Subunit**

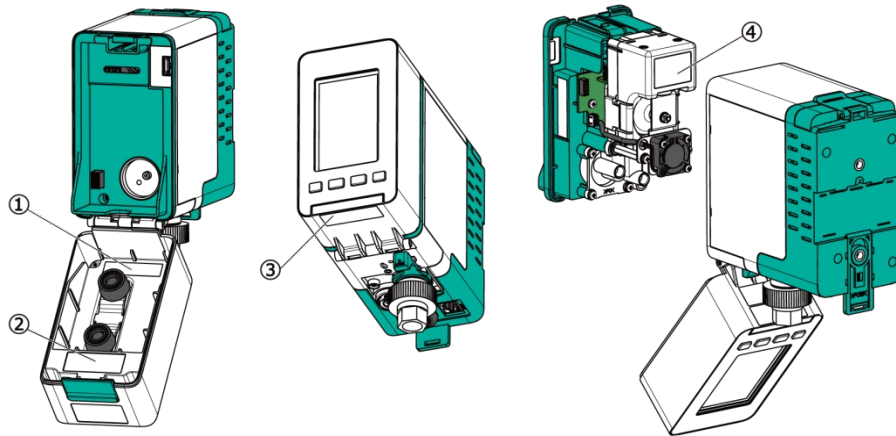

Item	Description
①	<b>Serial number label</b> Indicates the serial number of the product.
②	<b>Power rating label</b> Indicates the model and the power supply specifications.
③	<b>Environmental label</b> Indicates the applicable certification markings.
④	<b>Pump serial number label</b> Indicates the serial number of the pump.

**Labels for Expansion Unit**

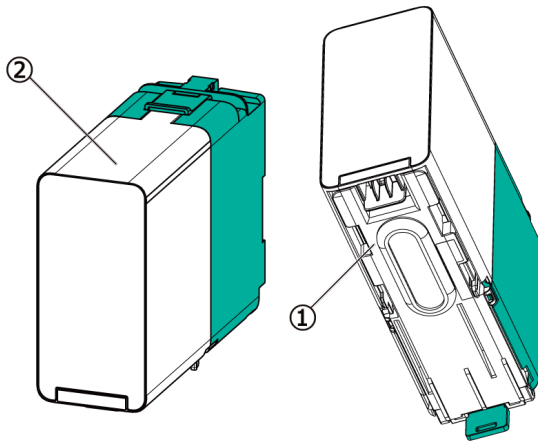

Item	Description
①	<b>Serial number label</b> Indicates the serial number of the product and applicable certification markings.
②	<b>Caution label</b> Indicates the precautions to be adopted while removing the front case.

## CE Marking

This product complies with the CE marking requirements.

Refer to the EU Declaration of Conformity before use.

Note: CE marking applies only when the maximum load for the gas alarm/fault alarm contacts of 30 VDC 1.0 A (resistive load) is used.

## 1.4 Disposal

Used product, components, sensor units, and/or batteries must be disposed of as hazardous waste in accordance with the applicable laws and regulations.

## 1.5 Service Life

The service life of this product is 10 years. The unit can operate for up to 10 years with standard installation and operation in accordance with the PS-8 series instruction manuals for installation and operation. When the service life has expired, replacement is essential for continued reliable performance and other purposes. "10 years" is only an estimate, and no guarantee is provided.

### Ref.

Refer to 12 "Maintenance" of the PS-8 Series Instruction Manual for Operation for the replacement parts, which may require replacement before this product's service life (10 years) expires.

## 1.6 Definition of Supervisor/Operator/Service Personnel

This manual is intended for personnel concerned with the use/installation/maintenance of this product. Concerned personnel are divided into three categories according to safety level, skills, and experience. This manual specifies the name of the applicable category and shows that the information or instruction given below applies to that category only.

<b>Supervisor</b>	<p>Manages the product operation.</p> <ul style="list-style-type: none"> <li>Fully understands the product operation method, entire gas alarm facility, and gas/fault alarm clearance method.</li> <li>Should carefully read this manual and be familiar with the system characteristics and relevant work activities.</li> </ul>
<b>Operator</b>	<p>Operates the product.</p> <ul style="list-style-type: none"> <li>Understands the product operation method, the way to address gas/fault alarms, and daily work activities for the product under the supervisor's instruction.</li> </ul>
<b>Service Personnel</b>	<p>Carries out installation, failure cause investigation, maintenance and repair work for the product.</p> <ul style="list-style-type: none"> <li>Requires special knowledge and skills for installation, maintenance, and repair.</li> </ul> <p>Acts as New Cosmos authorized technician in principle.</p>

## 2 System Configuration

This section explains the PS-8 system configuration.

Up to three subunits and up to four expansion units (up to eight modules, two modules per expansion unit) can be connected to a single main unit to form a gas detection system (a maximum of 4 channels or 4 gases).

Up to eight external gas detectors can be connected to the system via AI modules (two external gas detectors per AI module).

A main unit can be used as a stand-alone detector as well.

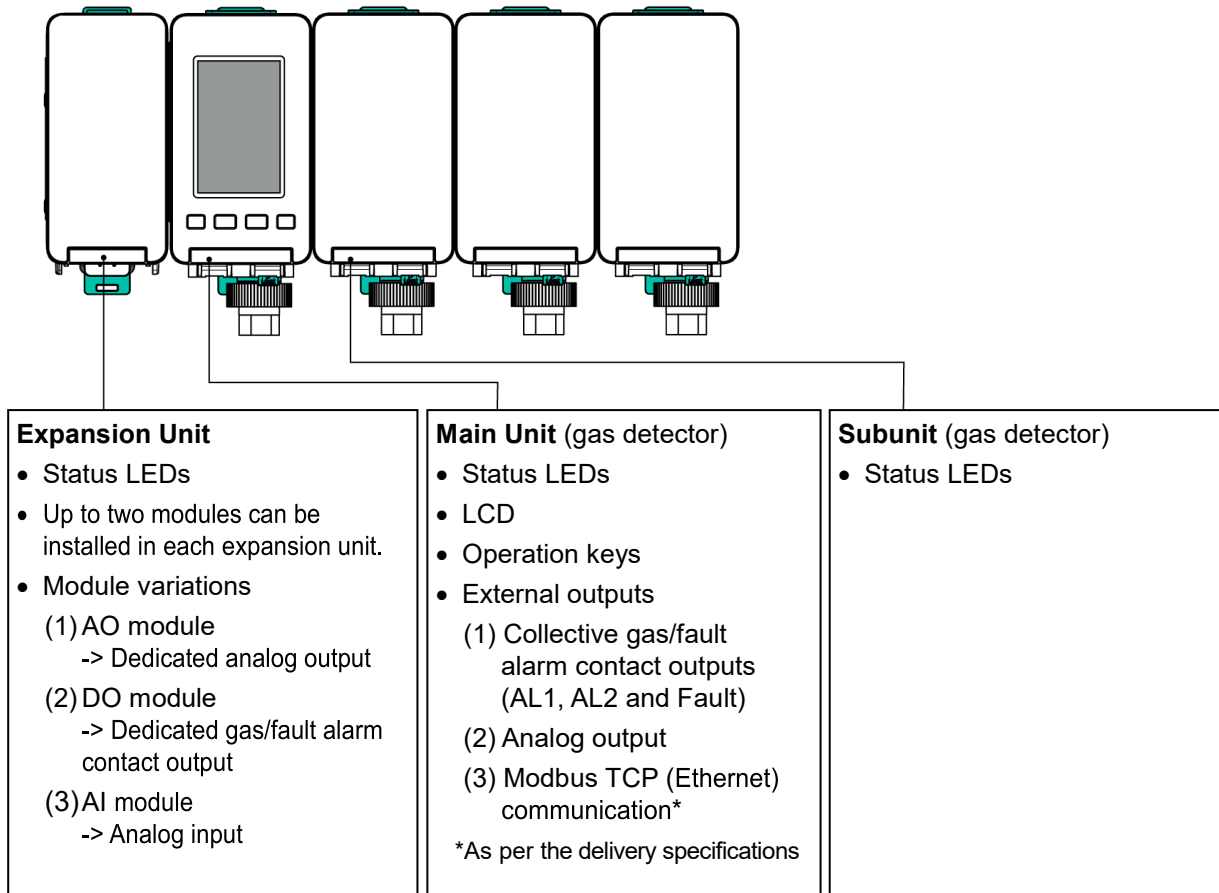

## 3 Communication Specifications

This section explains the communication specifications of this product. The communication system of this product consists of a master and a slave, and is a single-master/multi-slave communication system. As a Modbus slave device, this product can send and receive data to and from a Modbus master device (host device).

The Modbus master device (host device) can be a computer or programmable logic controller (PLC), or in the case of Modbus TCP communication, a fieldbus controller.

### 3.1 Modbus TCP Communication Specifications

Modbus TCP (Ethernet) communication specifications are shown in the table below.

Item	Specification
Communication protocol	Modbus compliant (TCP/IP)
Communication specification	Ethernet
Communication interface	RJ-45, Ethernet IEEE 802.3at
Connection type	Single-master/multi-slave system
Port No.	502 (Fixed: Modbus)
Electrical specification	10BASE-T/100base-Tx
Maximum number of connected units	2 units
Maximum transmission distance	100 m (distance to switching hub)
Connecting cable	Shielded twisted pair (STP) cable (Category 5e or higher)
IP address	192.168.0.101 (factory default) Can be changed in device setting.

# 4 Connection Specifications

This section explains the connection specifications of this product.

## 4.1 Communication System Configuration

This section explains an example of the communication system configuration.

### Modbus TCP (Ethernet)

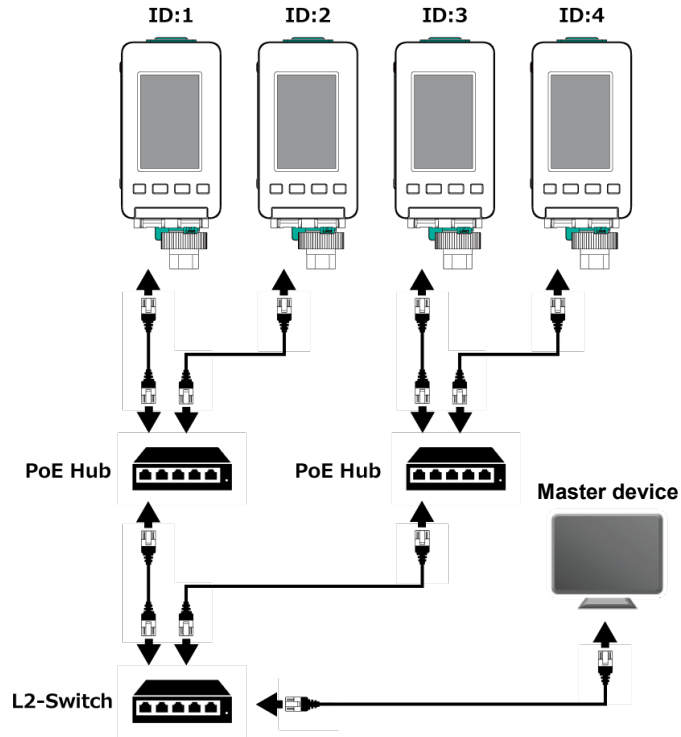

**NOTE**

- When the switching hub (HUB) is not PoE-compatible, supply 24VDC power to the PS-8.
- When connecting the fieldbus controller as Modbus TCP master, connect it to the L2-Switch.

**⚠ CAUTION**

-  The number of units to be connected varies depending on the connection-destination Modbus master device (host device). Check and verify the specifications of the connection-destination Modbus master device (host device).



#### 4.1.1 Example of Checking the Specifications of the Modbus Master Device (Host Device)

The check contents of specifications are described for a case of using the RJ71EN71 Ethernet Interface Unit of the PLC iQ-R Series by Mitsubishi Electric Corporation as an example. Perform the system design with reference to the following.

When connecting to the PS-8M (Main Unit) using the simple CPU communication function, the maximum number of units that can be connected per Ethernet port is 64. If the second Ethernet port is also used, a maximum of 128 units can be connected.

If the PS-8S (Sub Unit) is used, a maximum of four times the number of above units can be connected.

If the AI module of the Sub Unit and Expansion Unit is used, a maximum of 12 times the number of above units can be connected.

**NOTE**

- The periodic exchange setting of the simple CPU communication function is recommended to be 200 msec.
- The IP address is not set for the PS-8S Sub Units and Expansion Units. Set the IP address only for the PS-8M Main Unit.

## 4.2 Wiring

Be sure referring to the "PS-8 Series Instruction Manual for Installation" for information on wiring for Modbus (Ethernet) communication.



### WARNING



- Turn the power switch OFF when installing or wiring this product. Failure to do so may result in electric shock.



### CAUTION



- Refer to "7.4 Wiring Connection" in the "PS-8 Series Instruction Manual for Installation" for precautions when wiring terminals except for Modbus communication terminals.
- Refer to "7.4 Wiring Connection" in the "PS-8 Series Instruction Manual for Installation" and the separate delivery specifications, if any, to confirm that the connections of each part are correct before turning on the power.
- The analog outputs of this product are not isolated from the power supply. When using this product in combination with other devices, isolate the analog outputs of this product so that other power supplies do not come in contact with them.
- Avoid noise sources such as large-capacity transformers, motors, or power supplies.
- Connect cables as far away from other power lines (electric power lines), etc. as possible.
- Wire the cables in such a way that they are not stressed.

## 5 Communication settings

This section explains the Modbus (Ethernet) communication settings for this product.

 <b>CAUTION</b>	
	<ul style="list-style-type: none"> <li>If the communication specifications do not match those of the Modbus master device (host device) to be connected to this product, it may cause malfunctions such as failure to communicate properly.</li> </ul>

### 5.1 Communication Mode Setting

This section explains the setting method of the communication mode.  
From "Menu" → "Device Information" → "Modbus", select [TCP/IP].

### 5.2 Modbus TCP (Ethernet) Setting

#### 5.2.1 Target Browser



The web server has been tested to work with Microsoft Edge and Google Chrome. If you use other browsers, it may not work properly.

#### 5.2.2 IP Address Setting

When connecting to DHCP server, set "Device Information" → "DHCP" to [ON] to automatically obtain an IP address.

Otherwise, it must be set to [OFF] and the IP address and subnet mask must be set manually.

The upper 3 bytes of the IP address must be the same for both this product and the PC side, and the least significant byte must be a different value.

 <b>CAUTION</b>	
	<ul style="list-style-type: none"> <li>Addresses can be freely set within the configurable range, but should not duplicate the addresses of other devices.</li> </ul>

#### <This Product Setting>

Set the IP address, subnet mask, and default gateway of this product.

The IP address and subnet mask can be set in "Device Information" → "IP address/Subnet mask".

Example · · · IP address: 192.168.0.101

Subnet mask: 255.255.255.0

Default gateway: 0.0.0.0

#### NOTE

- For details on this product's operation, please refer to the "PS-8 Series Instruction Manual for Operation".

### <PC Setting>

---

Set the IP address of PC.

Open and change the Internet Protocol (TCP/IP) properties.

Example · · · IP address: 192.168.0.102  
Subnet mask: 255.255.255.0  
Default gateway: 0.0.0.0

### 5.2.3 Network Environment Setting

This product cannot be used via a proxy server.

Turn off the proxy server setting on the PC.

### 5.2.4 Communication check

Check that communication is normal.

#### <PC Side>

---

Open the web browser and enter the IP address of this product "e.g. <http://192.168.0.101>" in the address bar. Once accessed, gas information for each Ch. will be displayed.

#### NOTICE

If communication is not possible, check the following

- Ethernet communication of this product is OFF.  
⇒Check by using "Device Information" → "Ethernet".
- Modbus communication of this product is TCP/IP.  
⇒Check by using "Device Information" → "Modbus".
- Connection to this product, IP address and other settings.

## 6 Communication Protocol

This section explains the following communication protocols.

### 6.1 Overview of Modbus Communication Protocol

Modbus communication is a single-master/multi-slave communication system.

Modbus communication always works in the form of "the master initiates communication and sends a command message, and the slave (this product) sends a response message to the message from the master".

#### NOTE

- A communication interval of 200 msec or more is recommended.

#### 6.1.1 Message Configuration

The message frame configuration of Modbus communication consists of four parts: unit number (IP address), function code, data, and error check code, which are send in the following order.

	Message data	Data size
(1) Address	Unit number (IP address)	1 byte
(2) Function	Function code	1 byte
(3) Data	Data	Variable length (max. 125 words (250 bytes))
(4) CRC Check	Error check code	2 bytes

#### NOTE

- The message frame configuration for Modbus TCP (Ethernet) communication does not include "(4) CRC Check: Error check code".

#### (1) Unit number (IP address)

Only slaves for which the unit number (IP address) of the slave specified by the master and the unit number (IP address) set by the slave match will execute the contents of the command message. When the unit number (IP address) does not match, the slave does not respond to the master. In the case of Modbus TCP (Ethernet) communication, the IP address value is used.

#### NOTE

- Refer to "5.2.2 IP Address Setting" for information on setting the address setting switch.

#### CAUTION



- Addresses can be freely set within the configurable range, but should not duplicate the addresses of other devices.

**(2) Function code**

The function code is a code that specifies the function to be executed by the slave. The slave executes the specified function according to the function code supported by the slave (this product). After the slave successfully executes the function, the same function code is returned with the response message.

- Refer to "6.2 Function Codes" for the function codes supported by this product.
- For each function code, a register number is allocated to read/write data in Modbus communication.
- There are four types of registers: "Coil," "Input status," "Input register," and "Holding register," and the address range that can be read/written differs for each register.
- From "6.2 Function Codes" that this product supports, the Modbus register where this product's data is stored is the "Holding register".
- The address range of the holding register is 40001 to 49999 in the Modbus communication protocol, and data such as the setting information of this product is located in this range.

**NOTE****(3) Data**

The data required for the slave to execute according to the function code. The data configuration varies depending on the function code. It consists of a start address (register number), number of data, or data to be written, etc.

The data size is variable and can be maximum 125 words (250 bytes).

**NOTE**

- Refer to "6.2 Function Codes" for the function codes supported by this product.
- The maximum data size varies for each function code.

**6.1.2 Communication Procedures**

This section explains the communication procedure for Modbus communication.

1. **The master sends a command message to the slave (this product).**
2. **The slave (this product) determines whether the unit number (IP address in the case of Modbus TCP) in the command message matches the address of its own station. The master specifies the unit number (IP address in the case of Modbus TCP) to enable individual Modbus communication among multiple slaves on the same communication line.**

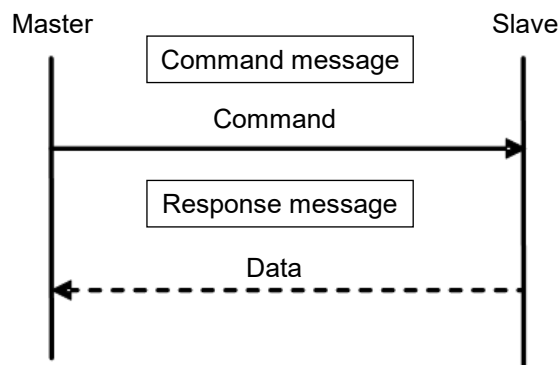

3. **If the addresses match, the slave (this product) executes the function according to the contents of the command message and creates the response message. In the case of error response, it creates the error response message including the exception code.**

**NOTE**

- Refer to "6.4.4 Error Response Message Communication Example" for the message configuration when responding to error.

- If the addresses do not match, the slave discards the command message and waits for the next command message (no response state).
- After sending command messages, the master should receive and confirm response messages from slaves.

If there is no response from the specified slave or error response message (exception code) is received, perform communication error processing.

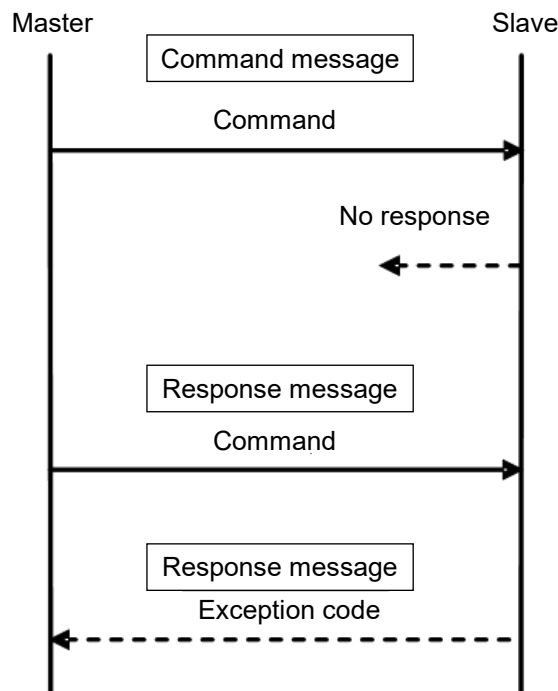

## 6.2 Function Codes

This product supports the following list of function codes.

Function code		Function	Max. data (words)	Remarks
No. (Decimal)	(Hex) (Hexadecimal)			
03	0x03	Single data or multiple data read	125	Holding register address area: 40001 to 49999 Gas concentration values, status information, alarm failure-related and other device setting information
06	0x06	Single data write	1	
16	0x10	Multiple data continuous write	123	

**NOTE**

- The data access unit of the register is 16-bit data length (1 word)
- The address range where data used in this product is located is 40001 to 42984.

## 6.3 Response of Error Occurs

This section explains the response when error occurs in Modbus communication.

When the content of a command message from the master is identified as error, the slave (this product) does not execute the command, but creates and returns error response messages.

When error response messages are returned from the slave (this product), the master should check the contents of the message.

### 6.3.1 Error Codes (Exception Codes)

The error codes (exception codes) supported by this product are shown in the table below.

Error codes (Hex)	Error items	Error conditions
0x01	Invalid function code	<ul style="list-style-type: none"> <li>When the function code not supported by this product is received.</li> </ul>
0x02	Invalid address error	<ul style="list-style-type: none"> <li>When the Modbus register number not defined in this product is received.</li> <li>When writing to the read-only register.</li> </ul>
0x03	Invalid data error	<ul style="list-style-type: none"> <li>When writing invalid data (out-of-range data) to the data defined in this product.</li> </ul>
0x06	Slave device busy	<ul style="list-style-type: none"> <li>When writing to the register while the setting is being changed by other operations.</li> </ul>

- Refer to "6.2 Function Codes" for the function codes supported by this product.
- The maximum data size varies for each function code.
- If the read/write start register number of the command message is the address (reserved area) not defined in this product, the invalid address error occurs. However, if the address not defined in this product (reserved area) is included in the read/write range instead of the read/write start register number, the invalid address error will not occur. Note that writing to reserved areas or read-only registers is invalid.
- Reading data from the reserved area or write-only register is set to "0" (word size).
- The data contents of reserved items may change during operation, so please do not handle the data on the system.

#### NOTE



## 6.4 Example of Message Communication

This section describes examples of command/response message communication for each function code supported by this product, as well as examples of message communication for error responses.

### 6.4.1 Function Code No. 03 (Holding Register Read) Communication Example

Function code 03 (0x03 hex) is the function code to read the data of the specified register number in the holding register.

#### Command Message Example

Send the function code = 03 (0x03 hex) from the master to the slave with unit number = 01.

Read 2 words of data for "Current gas concentration value (integer)" and "Decimal point position" located at register number 40005 (relative address = 4 (0x004 hex)).

Message frame			Modbus TCP communication			Remarks
Data item		Data size (byte)	Data No.	Byte data	Hexadecimal (Hex)	
Transfer ID	Hi	2	(1)	0	0x00	Modbus TCP communication only
	Lo		(2)	0	0x00	
Protocol ID	Hi	2	(3)	0	0x00	Modbus TCP communication only Fixed at "00"
	Lo		(4)	0	0x00	
Number of communication data	Hi	2	(5)	6	0x00	Modbus TCP communication only Number of data after unit ID
	Lo		(6)		0x06	
Unit No.		1	(7)	1	0x01	
Function code		1	(8)	3	0x03	
Start address	Hi	2	(9)	4	0x00	Read start register No.
	Lo		(10)		0x04	
Number of registers to read (words)	Hi	2	(11)	0	0x00	Number of data to be read: 1 to 125 bytes x 2 Unit is word size
	Lo		(12)	2	0x02	

### Response Message Example

Send the current gas concentration value = 25.3%F.S. (0x00FDhex) and the decimal point position = 1 (0x0001 hex) as a response message from the slave to the master.

The gas concentration data is hexadecimal data, which is the concentration value multiplied by 10 times the content of the decimal point position, so the value becomes 253 when the concentration value = 25.3.

Message frame			Modbus TCP communication			Remarks
Data item	Data size (byte)	Data No.	Byte data	Hexadecimal (Hex)		
Transfer ID	Hi	2	(1)	0	0x00	Modbus TCP communication only
	Lo		(2)	0	0x00	
Protocol ID	Hi	2	(3)	0	0x00	Modbus TCP communication only Fixed at "00"
	Lo		(4)	0	0x00	
Number of communication data	Hi	2	(5)	13	0x00	Modbus TCP communication only Number of data after unit ID
	Lo		(6)		0x0D	
Unit No.	1	(7)	1	0x01		
Function code	1	(8)	3	0x03		
Number of data (bytes)	1	(9)	4	0x04	Number of response data (bytes) = N x 2 (bytes) (N: Number of registers = 1 to 125 (words))	
Data 1	Hi	2	(10)	253	0x00	Response data: Transmitted in byte units in the order of Data1, Data2, etc., from upper to lower
	Lo		(11)		0xFD	
Data 2 (Final data)	Hi	2	(12)	1	0x00	
	Lo		(13)		0x01	

### 6.4.2 Function Code No. 06 (Holding Register Write) Communication Example

Function code 06 (0x06 hex) is the function code to write 1 word of data to the specified register number in the holding register.

#### Command Message Example

Send the function code = 06 (0x06 hex) from the master to the slave with unit number = 01.

Write 1 word (2 bytes) of data to Sensor 1 "Maintenance mode" located at register number 40390 (relative address = 389 (0x0185 hex)).

Maintenance mode 2 = 2 (0x0002 hex)

Message frame			Modbus TCP communication			Remarks
Data item	Data size (byte)	Data No.	Byte data	Hexadecimal (Hex)		
Transfer ID	Hi	2	(1)	0	0x00	Modbus TCP communication only
	Lo		(2)	0	0x00	
Protocol ID	Hi	2	(3)	0	0x00	Modbus TCP communication only Fixed at "00"
	Lo		(4)	0	0x00	
Number of communication data	Hi	2	(5)	6	0x00	Modbus TCP communication only Number of data after unit ID
	Lo		(6)		0x06	
Unit No.	1	(7)	1	0x01		
Function code	1	(8)	6	0x06		
Start address	Hi	2	(9)	389	0x01	Write start register No.
	Lo		(10)		0x85	
Data	Hi	2	(11)	2	0x00	Write data: Data size is in words
	Lo		(12)		0x02	

### Response Message Example

Send the result of writing 2 (1 word) to the sensor 1 maintenance mode as a response message from the slave to the master.

Maintenance mode = 2 (0x0002 hex)

Message frame		Modbus TCP communication				Remarks
Data item	Data size (byte)	Data No.	Byte data	Hexadecimal (Hex)		
Transfer ID	Hi	2	(1)	0	0x00	Modbus TCP communication only
	Lo		(2)	0	0x00	
Protocol ID	Hi	2	(3)	0	0x00	Modbus TCP communication only Fixed at "00"
	Lo		(4)	0	0x00	
Number of communication data	Hi	2	(5)	6	0x00	Modbus TCP communication only Number of data after unit ID
	Lo		(6)		0x06	
Unit No.		1	(7)	1	0x01	
Function code		1	(8)	6	0x06	
Start address	Hi	2	(9)	389	0x01	
	Lo		(10)		0x85	
Write data	Hi	2	(11)	2	0x00	Write data: Data size is in words
	Lo		(12)		0x02	

### 6.4.3 Function Code No. 16 (Holding Register Continuous Write) Communication Example

Function code 16 (0x10 hex) is the function code for writing continuous data to multiple registers from the specified register number in the holding register.

#### Command Message Example

Send the function code = 16 (0x10 hex) from the master to the slave with unit number = 01.

Write continuous data to multiple registers of register number 40391 (relative address = 390 (0x0186 hex)) "Alarm test shifting ON/OFF" and register number 40392 (relative address = 391 (0x0187 hex)) "Alarm test mode".

Alarm test shifting = ON (0x0001 hex)

Alarm test mode setting = 25.3% F.S. (0x00FD hex)

Message frame		Modbus TCP communication			Remarks	
Data item	Data size (byte)	Data No.	Byte data	Hexadecimal (Hex)		
Transfer ID	Hi	2	(1)	0	0x00	Modbus TCP communication only
	Lo		(2)	0	0x00	
Protocol ID	Hi	2	(3)	0	0x00	Modbus TCP communication only Fixed at "00"
	Lo		(4)	0	0x00	
Number of communication data	Hi	2	(5)	11	0x00	Modbus TCP communication only Number of data after unit ID
	Lo		(6)		0x0B	
Unit No.		1	(7)	1	0x03	
Function code		1	(8)	16	0x10	
Start address	Hi	2	(9)	390	0x01	Write start register No.
	Lo		(10)		0x86	
Number of registers	Hi	2	(11)	2	0x00	Number of write registers 1 to 123 (words)
	Lo		(12)		0x02	
Number of data (bytes)		1	(13)	4	0x04	Number of response data (bytes) = N x 2 (bytes) (N: Number of registers (words))
Data 1	Hi	2	(14)	1	0x00	Write data: Data size is in words
	Lo		(15)		0x01	
Data 2	Hi	2	(16)	253	0x00	
	Lo		(17)		0xFD	

### Response Message Example

Send the result of continuous data writing to multiple registers as a response message from the slave to the master.

Message frame		Modbus TCP communication			Remarks	
Data item	Data size (byte)	Data No.	Byte data	Hexadecimal (Hex)		
Transfer ID	Hi	2	(1)	0	0x00	Modbus TCP communication only
	Lo		(2)	0	0x00	
Protocol ID	Hi	2	(3)	0	0x00	Modbus TCP communication only Fixed at "00"
	Lo		(4)	0	0x00	
Number of communication data	Hi	2	(5)	6	0x00	Modbus TCP communication only Number of data after unit ID
	Lo		(6)		0x06	
Unit No.		1	(7)	1	0x01	
Function code		1	(8)	16	0x10	
Start address	Hi	2	(9)	390	0x01	Write start register No.
	Lo		(10)		0x86	
Number of registers	Hi	2	(11)	2	0x00	Number of write registers 1 to 123 (words)
	Lo		(12)		0x02	

### 6.4.4 Error Response Message Communication Example

Send the error response message to the master in the following configuration.

The function code for error response is used for the function code of the error response message with "1" set (function code plus 0x80 (hex)) in the most significant bit (MSB) of the command message function code.

- (1) Unit No.: 1 byte
- (2) Error function code: 1 byte
- (3) Error code (exception code): 1 byte
- (4) Error check code: 2 bytes

Error function code example:

If an error occurs in a command message with the function code 0x06 (hex), 0x86 (hex) is added to the error response message as an error function code using "0x80 + 0x06 (hex)".

#### NOTE

- For Modbus TCP (Ethernet) communication, the unit number is 0. Refer to "5.2.2 IP Address Setting" for information on setting the address setting switch.

The example response message when the error occurs is as follows.

#### Command Message Example

Send function code = 16 (0x10 hex) from the master to the slave with unit number = 03.

This product writes continuous data to multiple registers starting at register number 40100 (relative address = 99 (0x0063 hex)), which is not defined.

#### Response Message Example

Send the error response message from the slave to the master as follows.

Message frame			Modbus TCP communication			Remarks
Data item		Data size (byte)	Data No.	Byte data	Hexadecimal (Hex)	
Transfer ID	Hi	2	(1)	0	0x00	Modbus TCP communication only
	Lo		(2)	0	0x00	
Protocol ID	Hi	2	(3)	0	0x00	Modbus TCP communication only Fixed at "00"
	Lo		(4)	0	0x00	
Number of communication data	Hi	2	(5)	3	0x00	Modbus TCP communication only Number of data after unit ID
	Lo		(6)		0x03	
Unit No.		1	(7)	3	0x03	
Error function code		1	(8)	144	0x90	Result of adding 0x80hex to function code 0x10hex
Error code		1	(9)	2	0x02	Exception code = Invalid address error

## 6.5 Register Address Maps

This section explains the register address map where the data used by this product is located.

In this product, data such as gas concentration values, status information, and device settings are located in holding registers as the storage destination.

It reads and writes the data located in the register number specified in the command message from the master.

The register address map for Modbus communication is shown in the table below.

Register numbers 40001 to 40124 and 40126 to 40249 have the same information, but the data type of the concentration information is different. To read out concentration information as "integer + decimal point position", use register numbers 40001 to 40124. To read out concentration information in "floating point", use register numbers 40126 to 40249.

- Refer to "6.2 Function Codes" for the function codes supported by this product.
- The maximum data size varies for each function code.
- If the read/write start register number of the command message is the address (reserved area) not defined in this product, the invalid address error occurs.

### NOTE

However, if the address not defined in this product (reserved area) is included in the read/write range instead of the read/write start register number, the invalid address error will not occur. Note that writing to reserved areas or read-only registers is invalid.

- Reading data from the reserved area or write-only register is set to "0" (word size).
- The data contents of reserved items may change during operation, so please do not handle the data on the system.
- To determine whether a command execution succeeded, reload the status and concentration values.

Register No.	Relative address		Words	Unit	Sensor Ch.	Register item	Access	Type	Data contents
	Dec	hex							
40001	0	0	2	Sensor	1	Status / Fault simulation test status	R	DWord	<p>It reads the status of sensor 1 or the Fault simulation test mode status (in fault simulation test).</p> <p>0: Fault simulation test OFF 1: Fault simulation test ON</p> <p>bit31: Heartbeat bit30~bit23: Reservation bit22: Maint mode collective flag (Target of collective: bit14~bit11) bit21: Fault collective flag (Target of collective: bit7~bit4) bit20: In monitoring mode (No fault, alarm, maintenance, warm-up, or testing) bit19: Over range bit18: Abnormalities in continued operation (Bits 16, 17, 19 and 20 of failure detail status) bit17: Reservation bit16: Warm-up bit15: Test mode bit14: Maint mode C2 (When setting by external operation) bit13: Maint mode C1 (When setting by external operation) bit12: Maint mode M2 (When setting by device operation) bit11: Maint mode M1 (When setting by device operation) bit10: Reservation bit9: Reservation bit8: Reservation bit7: Interunit comm. failure bit6: Device failure ( bit11 to bit3 of failure detail status) bit5: Fan failure bit4: Sensor-related collective failure (Target of collective: bit2 to bit0 of failure detail status) bit3: Low flow failure bit2: Preliminary alarm (Zero suppr. exceeded at the alarm side) bit1: Alarm 2 bit0: Alarm 1</p> <p>During maintenance mode, Bit0 to bit10 and bit18 to bit21 are masked to 0.</p>

Register No.	Relative address		Words	Unit	Sensor Ch.	Register item	Access	Type	Data contents
	Dec	hex							
40003	2	2	2	Sensor	1	Fault detail status / Fault detail status in fault simulation test mode	R	Word	It reads the fault detail status or the fault detail status of fault simulation test mode (in fault simulation test). 0: Fault simulation test OFF 1: Fault simulation test ON bit31: Reservation bit30: Reservation bit29: Reservation bit28: Reservation bit27: Reservation bit26: Reservation bit25: Reservation bit24: Reservation bit23: Reservation bit22: Reservation bit21: Reservation bit20: NAND FLASH abnormal bit19: Abnormal date/time setting bit18: Reservation bit17: Mail send error bit16: Time synchronization error bit15: Reservation bit14: Reservation bit13: Reservation bit12: Reservation bit11: Reservation bit10: Ethernet comm. failure bit9: SDRAM failure bit8: NOR FLASH failure bit7: EEPROM failure bit6: Power failure bit5: Parameter info. failure bit4: Module setting failure bit3: Pump unit failure bit2: Sensor unit EEPROM failure bit1: Sensor type mismatch bit0: Sensor failure
40005	4	4	1	Sensor	1	Concentration (integer)	R	Word	The gas concentration value (integer) is read. Example: For 20.9 vol%, the value is 0x00D1(hex)=(209). The content of the decimal point position is set as x, and the value multiplied by 10 <sup>x</sup> is read out. For 20.9vol%, the decimal point position is 1.
40006	5	5	1	Sensor	1	Decimal point	R	Word	The decimal point position of the concentration (integer) is read. 0: No decimal point 1: Decimal point at the 1st digit 0.1 for concentration (integer) 1 2: Decimal point at the 2nd digit 0.11 for concentration (integer) 11 3: Decimal point at the 3rd digit 0.111 for concentration (integer) 111
40007	6	6	1	Sensor	1	Flow rate	R	Word	The flow rate is read as a FL value. Example: 0x1F4 (hex) for FL500



Register No.	Relative address		Words	Unit	Sensor Ch.	Register item	Access	Type	Data contents
	Dec	hex							
40008	7	7	7	Sensor	2	Same as Sensor1 (periodic data) Status Fault detail status Concentration (integer) Decimal point Flow rate	R	Word	Register items and data contents are the same as Sensor1, refer to relative address 0 to 7. Concentration data is the integer value.
40015	14	E	7	Sensor	3				
40022	21	15	7	Sensor	4				
40029	28	1C	7	Sensor	5				
40036	35	23	7	Sensor	6				
40043	42	2A	7	Sensor	7				
40050	49	31	7	Sensor	8				
40057	56	38	7	Sensor	9				
40064	63	3F	7	Sensor	10				
40071	70	46	7	Sensor	11				
40078	77	4D	7	Sensor	12				
40085	84	54	7	Sensor	13				
40092	91	5B	7	Sensor	14				
40099	98	62	7	Sensor	15				
40106	105	69	7	Sensor	16				
40113	112	70	1	Common		Heartbeat	R	Word	It reads whether the device is operating or not. The value is incremented by +1 every second. After going up to 255, it returns to 0.
40114	113	71	8	Common		Relay output monitor	R	Word	It reads the state of the contact. 8 bits are equivalent to 1 sensor. bit7 to 3: Spare bit2: Relay (Fault) bit1: Relay (Alarm 2) bit0: Relay (Alarm 1) The status is read out in the order of Sensor1 (upper), Sensor2 (lower), and so on up to Sensor16.
40122	121	79	1			Reservation			Reservation
40123	122	7A	1			Reservation			Reservation
40124	123	7B	1	Common		Setting changes Channel information	R/W	Word	It reads whether the setting has been changed or not. If the target item in the setting change notification is changed, the target bit is set from 0 to 1 according to the changed channel. Change notifications are subject to the register item marked 'change notification'. After the change notification is read, Modbus client writes 0 to the target bit. The channels corresponding to each bit are as follows. 0bit: 1Ch 1bit: 2Ch 2bit: 3Ch 3bit: 4Ch 4bit: 5Ch 5bit: 6Ch 6bit: 7Ch 7bit: 8Ch 8bit: 9Ch 9bit: 10Ch 10bit: 11Ch 11bit: 12Ch 12bit: 13Ch 13bit: 14Ch 14bit: 15Ch 15bit: 16Ch
40125	124	7C	1			Reservation			Reservation
40126	125	7D	2	Sensor	1	Fault simulation test mode (status)	R	Word	Same as relative address 0.
40128	127	7F	2	Sensor	1	Fault simulation test mode (fault detail status)	R	Word	Same as relative address 2.
40130	129	81	2	Sensor	1	Concentration (floating point)	R	Word	It reads the concentration in floating point (IEEE754 single precision). Example: For 20.9 vol%: 0x41A73333(hex) Upper word: 0x3333(hex) Lower word: 0x41A7(hex)

Register No.	Relative address		Words	Unit	Sensor Ch.	Register item	Access	Type	Data contents
	Dec	hex							
40132	131	83	1	Sensor	1	Flow rate	R	Word	Same as relative address 6.
40133	132	84	7	Sensor	2	Same as Sensor1 (periodic data) Status Fault detail status Concentration (floating point) Flow rate	R	Word	Register items and data contents are the same as Sensor1, refer to relative address 125 to 131. Concentration part is the floating point.
40140	139	8B	7	Sensor	3				
40147	146	92	7	Sensor	4				
40154	153	99	7	Sensor	5				
40161	160	A0	7	Sensor	6				
40168	167	A7	7	Sensor	7				
40175	174	AE	7	Sensor	8				
40182	181	B5	7	Sensor	9				
40189	188	BC	7	Sensor	10				
40196	195	C3	7	Sensor	11				
40203	202	CA	7	Sensor	12				
40210	209	D1	7	Sensor	13				
40217	216	D8	7	Sensor	14				
40224	223	DF	7	Sensor	15				
40231	230	E6	7	Sensor	16				
40238	237	ED	1	Common		Heartbeat	R	Word	Same as relative address 112.
40239	238	EE	8	Common		Relay output monitor	R	Word	Same as relative address 113.
40247	246	F6	1			Reservation			Reservation
40248	247	F7	1			Reservation			Reservation
40249	248	F8	1	Common		Setting changes Channel information	R/W	Word	Same as relative address 123
40250	249	F9	1			Reservation			Reservation
Main unit common									
40251	250	FA	1	Main		Alarm cancellation	W	Word	Write "Alarm cancellation" to cancel the alarm. Cancellation is possible when the setting is "Manual-resetting" and the concentration is at the alarm cancellation level. Cancellation: 0x0001 (hex)
40254	253	FD	1	Main		Alarm cancellation mode setting	R	Word	It reads the alarm mode setting. 0x0000 (hex): Auto-resetting 0x0001 (hex): Manual-resetting
40255	254	FE	1	Main		Collective contact (AL1)	R	Word	It reads the energized setting of the collective alarm contact (Alarm 1) of the main unit. 0x0000 (hex): Normally not energized 0x0001 (hex): Normally energized
40256	255	FF	1	Main		Collective contact (AL2)	R	Word	It reads the energized setting of the collective alarm contact (Alarm 2) of the main unit. 0x0000 (hex): Normally not energized 0x0001 (hex): Normally energized
40257	256	100	1	Main		Collective contact (Fault)	R	Word	It reads the energized setting of the collective fault contact of the main unit. 0x0000 (hex): Normally not energized 0x0001 (hex): Normally energized
40258	257	101	1	Main		Reservation			Reservation
40259	258	102	1	Main		Date and time (year, month)	R/W	Word	It is read/write the set date and time (year and month) of the device. Upper byte: month Lower byte: year (0 to 99) Example: March 2023 → 0x0317 (hex) * When reading/writing the date and time, it is necessary to do so in units of 3 words: (year, month), (day, hour), (minute, second).
40260	259	103	1	Main		Date and time (day, hour)	R/W	Word	It is read/write the set date and time (day and hour) of the device. Upper byte: hour (24 hours) Lower byte: day Example: 23:00 on 27th → 0x171B (hex) * When reading/writing the date and time, it is necessary to do so in units of 3 words: (year, month), (day, hour), (minute, second).

Register No.	Relative address		Words	Unit	Sensor Ch.	Register item	Access	Type	Data contents
	Dec	hex							
40261	260	104	1	Main		Date and time (minutes, seconds)	R/W	Word	It is read/write the set date and time (minutes and seconds) of the device. Upper byte: seconds Lower byte: minutes Example: 35 minutes and 05 seconds → 0x0523 (hex)  * When reading/writing the date and time, it is necessary to do so in units of 3 words: (year, month), (day, hour), (minute, second).
40262	261	105	4	Main		Serial No.	R	Char [8]	It is read the serial number as a character string. The character string is read in ASCII code (hexadecimal) every 2 bytes from the beginning, with the 2nd byte being the upper byte and the 1st byte being the lower byte. Example: In the case of '01234567' Upper byte: 0x31 (hex) '1' Lower byte: 0x30 (hex) '0' Upper byte: 0x33 (hex) '3' Lower byte: 0x32 (hex) '2' Upper byte: 0x35 (hex) '5' Lower byte: 0x34 (hex) '4' Upper byte: 0x37 (hex) '7' Lower byte: 0x36 (hex) '6'
40266	265	109	8	Main		Main unit tag name	R/W	Char [16]	The tag name of the main unit is read/written. The character string is read in ASCII code (hexadecimal) every 2 bytes from the beginning, with the 2nd byte being the upper byte and the 1st byte being the lower byte. Example: In the case of 'PS8-0123456789' Upper byte: 0x53 (hex) 'S' Lower byte: 0x50 (hex) 'P' Upper byte: 0x2D (hex) '-' Lower byte: 0x38 (hex) '8' Upper byte: 0x31 (hex) '1' Lower byte: 0x30 (hex) '0' Upper byte: 0x33 (hex) '3' Lower byte: 0x32 (hex) '2' Upper byte: 0x35 (hex) '5' Lower byte: 0x34 (hex) '4' Upper byte: 0x37 (hex) '7' Lower byte: 0x36 (hex) '6' Upper byte: 0x39 (hex) '9' Lower byte: 0x38 (hex) '8'
Each channel									
40301	300	12C	2	Sensor	1	Status	R	Word	Same as relative address 0.
40303	302	12E	2	Sensor	1	Fault detail status	R	Word	Same as relative address 2.
40305	304	130	1	Sensor	1	Concentration (integer)	R	Word	Same as relative address 4.
40306	305	131	1	Sensor	1	Decimal point	R	Word	Same as relative address 5.
40307	306	132	2	Sensor	1	Concentration (floating point)	R	Word	Same as relative address 129.
40309	308	134	1	Sensor	1	Alarm setting (AL1) (integer) (change notification)	R/W	Word	It is read/write the alarm (AL1) setting value (integer). Example: If the alarm (AL1) setting = 25.3, the value is 0x00FD (hex) (=253). The content of the decimal point position is set as x, and the value multiplied by 10 <sup>x</sup> is read out. For 25.3, the decimal point position is 1.
40310	309	135	1	Sensor	1	Alarm setting (AL2) (integer) (change notification)	R/W	Word	It is read/write the alarm (AL2) setting value (integer). Example: If the alarm (AL2) setting = 2.50, the value is 0x00FA (hex) (=250). The content of the decimal point position is set as x, and the value multiplied by 10 <sup>x</sup> is read out. For 25.3, the decimal point position is 2.

Register No.	Relative address		Words	Unit	Sensor Ch.	Register item	Access	Type	Data contents
	Dec	hex							
40311	310	136	2	Sensor	1	Alarm setting (AL1) (floating point) (change notification)	R/W	DWord	It is read/write the alarm setting (AL1) value in floating point (IEEE754 single-precision). Example: In the case of Alarm 1 value = 25.3, 0x41CA6666 (hex) Upper word: 0x6666 (hex) Lower word: 0x41CA (hex)
40313	312	138	2	Sensor	1	Alarm setting (AL2) (floating point) (change notification)	R/W	DWord	It is read/write the alarm setting (AL2) value in floating point (IEEE754 single-precision). Example: In the case of Alarm 2 value = 2.50, 0x40200000 (hex) Upper word: 0x0000 (hex) Lower word: 0x4020 (hex)
40315	314	13A	1	Sensor	1	Full scale value (integer) (change notification)	R/W*	Word	It is read/write the full scale value. *Can be written only when the unit allocation is the AI module. Example: In the case of 25.0 vol% full scale, the value is 0x00FA (hex) (=250). The content of the decimal point position is set as x, and the value multiplied by 10 <sup>x</sup> is read out. For 25.0 vol%, the decimal point position is 1.
40316	315	13B	1	Sensor	1	Decimal point (change notification)	R/W*	Word	It is read/write the decimal point position of the concentration (integer). *Can be written only when the unit allocation is the AI module. 0: No decimal point 1: Decimal point at the 1st digit 0.1 for concentration (integer) 1 2: Decimal point at the 2nd digit 0.11 for concentration (integer) 11 3: Decimal point at the 3rd digit 0.111 for a concentration (integer) of 111
40317	316	13C	2	Sensor	1	Full scale value (floating point) (change notification)	R/W*	Word	It is read/write the full scale value in floating point (IEEE754 single-precision). *Can be written only when the unit allocation is the AI module. Example: In the case of 25.0 vol% full scale, the value is 0x41C80000 (hex). Upper word: 0x0000 (hex) Lower word: 0x41C8 (hex)
40319	318	13E	1	Sensor	1	Unit (change notification)	R/W*	Word	It is read/write the unit code. *Can be written only when the unit allocation is the AI module. 0: no unit, 1: ppm, 2: ppb, 3: vol%, 4: %LEL, 5: %. Example: In the case of unit code = 1 (ppm), the value is 0x0001 (hex).
40320	319	13F	1	Sensor	1	Alarm mode (change notification)	R	Word	It is read out the alarm mode information. 0: Upper limit (AL1) - Upper limit (AL2): 0x0000 1: Lower limit (AL1) - Lower limit (AL2): 0x0001 2: Lower limit (AL1) - Upper limit (AL2): 0x0002
40321	320	140	8	Sensor	1	Gas name (change notification)	R/W	Char [16]	It is read/write the gas name of Sensor1. The character string is read in ASCII code (hexadecimal) every 2 bytes from the beginning, with the 2nd byte being the upper byte and the 1st byte being the lower byte. Example: In the case of 'PH3' Upper byte: 0x48 (hex) 'H' Lower byte: 0x50 (hex) 'P' Upper byte: 0x20 (hex) Space character Lower byte: 0x30 (hex) '3'

Register No.	Relative address		Words	Unit	Sensor Ch.	Register item	Access	Type	Data contents
	Dec	hex							
40329	328	148	8	Sensor	1	Tag name (change notification)	R/W	Char [16]	It is read/write the tag name of Sensor1. The character string is read in ASCII code (hexadecimal) every 2 bytes from the beginning, with the 2nd byte being the upper byte and the 1st byte being the lower byte. Example: In the case of 'PS8-0123456789' Upper byte: 0x53 (hex) 'S' Lower byte: 0x50 (hex) 'P' Upper byte: 0x2D (hex) '-' Lower byte: 0x38 (hex) '8' Upper byte: 0x31 (hex) '1' Lower byte: 0x30 (hex) '0' Upper byte: 0x33 (hex) '3' Lower byte: 0x32 (hex) '2' Upper byte: 0x35 (hex) '5' Lower byte: 0x34 (hex) '4' Upper byte: 0x37 (hex) '7' Lower byte: 0x36 (hex) '6' Upper byte: 0x39 (hex) '9' Lower byte: 0x38 (hex) '8'
40337	336	150	1	Sensor	1	Alarm delay time (AL1) (change notification)	R/W	Word	It is read/write the alarm delay time (AL1). Example: In the case of delay time = 5 (seconds), the value is 0x0005 (hex).
40338	337	151	1	Sensor	1	Alarm delay time (AL2) (change notification)	R/W	Word	It is read/write the alarm delay time (AL2). Example: In the case of delay time = 5 (seconds), the value is 0x0005 (hex).
40339	338	152	1	Main	1	Reservation			Reservation
40340	339	153	10	Main	1	Reservation			Reservation
40350	349	15D	1	Main	1	DO unit allocation	R	Word	It is read the ON/OFF DO module allocation. 0: OFF / 1: ON
40351	350	15E	1	Main	1	4-20 mA analog input allocation	R	Word	It is read the ON/OFF AI module allocation. 0: OFF / 1: ON
40352	351	15F	1	Main	1	Reservation			Reservation
40353	352	160	1	Sensor	1	Reservation			Reservation
40354	353	161	1	Sensor	1	Reservation			Reservation
40355	354	162	1	Sensor	1	Reservation			Reservation
40356	355	163	1	Sensor	1	Reservation			Reservation
40357	356	164	1	Sensor	1	Sensor days of use	R	Word	It is read the number of days sensor has been in use. Example: In the case of 60 days, 0x003C(hex)
40358	357	165	1	Sensor	1	Pump days of use	R	Word	It is read the number of days pump has been in use. Example: In the case of 60 days, 0x003C(hex)
40359	358	166	1	Sensor	1	% of Pump Duty	R	Word	It is read the control value of the pump. The control value is 0 to 100%. Example: In the case of 20%, 0x0014 (hex)
40360	359	167	4	Sensor	1	Sensor unit serial No.	R	Char [8]	It is read the sensor unit serial No. as a character string. The character string is read in ASCII code (hexadecimal) every 2 bytes from the beginning, with the 2nd byte being the upper byte and the 1st byte being the lower byte. Example: In the case of '01234567' Upper byte: 0x31 (hex) '1' Lower byte: 0x30 (hex) '0' Upper byte: 0x33 (hex) '3' Lower byte: 0x32 (hex) '2' Upper byte: 0x35 (hex) '5' Lower byte: 0x34 (hex) '4' Upper byte: 0x37 (hex) '7' Lower byte: 0x36 (hex) '6'
40370	369	171	1	Sensor	1	Heartbeat	R	Word	Same as offset address 112.
40371	370	172	10	Sensor	1	Reservation			Reservation
40383	382	17E	1	Sensor	1	Relay (Alarm1)	R/W	Word	It is read/write the energized setting of sensor1's alarm contact (Alarm1). 0x0000 (hex): Normally not energized 0x0001 (hex): Normally energized

Register No.	Relative address		Words	Unit	Sensor Ch.	Register item	Access	Type	Data contents
	Dec	hex							
40384	383	17F	1	Sensor	1	Relay (Alarm2)	R/W	Word	It is read/write the energized setting of sensor1's alarm contact (Alarm2). 0x0000 (hex): Normally not energized 0x0001 (hex): Normally energized
40385	384	180	1	Sensor	1	Relay (Fault)	R/W	Word	It is read/write the energized setting of sensor1's fault contact. 0x0000 (hex): Normally not energized 0x0001 (hex): Normally energized
40390	389	185	1	Sensor	1	Maint mode	R/W	Word	It is read/write the maintenance mode setting. 0: Maintenance mode OFF 1: Maintenance mode 1 2: Maintenance mode 2
40391	390	186	1	Sensor	1	Alarm test shift ON/OFF	R/W	Word	Alarm test mode is start/end. 0: Alarm test ends 1: Alarm test starts
40392	391	187	1	Sensor	1	Alarm test mode	R/W	Word	When the test concentration is entered, the input concentration is used as the gas concentration. Input in %FS. value. The decimal point follows the fixed-point setting. Example: In the case of F.S. 25.0, the full scale will be 250 and the fixed decimal point 1. If the alarm test value is set to 50, the test value will be 5.0. This is possible only when the alarm test is ON.
40393	392	188	2	Sensor	1	Alarm test mode (floating point)	R/W	Word	When the gas concentration is entered, the input concentration is used as the gas concentration. It is read/write the full scale value in floating point (IEEE754 single-precision). Example: In the case of value=25.3, the value is 0x41CA6666 (hex). Upper word: 0x6666 (hex) Lower word: 0x41CA (hex)
40395	394	18A	2	Sensor	1	Fault simulation test mode (status)	R/W	Word	It is read/write the status of sensor1's fault simulation test mode in each bit. 0: Fault simulation test OFF 1: Fault simulation test ON The bit contents of the status are the same as relative address 0.
40397	396	18C	2	Sensor	1	Fault simulation test mode (fault detail status)	R/W	Word	It is read/write the fault detail status of fault simulation test mode in each bit. 0: Fault simulation test OFF 1: Fault simulation test ON The bit contents of the status are the same as relative address 2.
40399 ~ 40401	398 ~ 400	18F ~ 190	3	Sensor	1	Reservation			Reservation
40402 ~ 40502	401 ~ 501	191 ~ 1F5	101	Sensor	2	Same item as relative addresses 300 to 396	R/W	Word	Same as relative addresses 300 to 396 Example (for status): Relative address 401, obtained by adding 101 to relative address 300, will have the status of sensor Ch. 2.
40503 ~ 40603	502 ~ 602	1F6 ~ 25A	101	Sensor	3	Same item as relative addresses 300 to 396	R/W	Word	Same as relative addresses 300 to 396 Example (for status): Relative address 502, obtained by adding 202 to relative address 300, will have the status of sensor Ch. 3.
40604 ~ 40704	603 ~ 703	25B ~ 2BF	101	Sensor	4	Same item as relative addresses 300 to 396	R/W	Word	Same as relative addresses 300 to 396 Example (for status): Relative address 603, obtained by adding 303 to relative address 300, will have the status of sensor Ch. 4.
40705 ~ 40805	704 ~ 804	2C0 ~ 324	101	Sensor	5	Same item as relative addresses 300 to 396	R/W	Word	Same as relative addresses 300 to 396 Example (for status): Relative address 704, obtained by adding 404 to relative address 300, will have the status of sensor Ch. 5.
40806 ~ 40906	805 ~ 905	325 ~ 389	101	Sensor	6	Same item as relative addresses 300 to 396	R/W	Word	Same as relative addresses 300 to 396 Example (for status): Relative address 805, obtained by adding 505 to relative address 300, will have the status of sensor Ch. 6.

Register No.	Relative address		Words	Unit	Sensor Ch.	Register item	Access	Type	Data contents
	Dec	hex							
40907 ~ 41007	906 ~ 1006	38A ~ 3EE	101	Sensor	7	Same item as relative addresses 300 to 396	R/W	Word	Same as relative addresses 300 to 396 Example (for status): Relative address 906, obtained by adding 606 to relative address 300, will have the status of sensor Ch. 7.
41008 ~ 41108	1007 ~ 1107	3EF ~ 453	101	Sensor	8	Same item as relative addresses 300 to 396	R/W	Word	Same as relative addresses 300 to 396 Example (for status): Relative address 1007, obtained by adding 707 to relative address 300, will have the status of sensor Ch. 8.
41109 ~ 41209	1108 ~ 1208	454 ~ 4B8	101	Sensor	9	Same item as relative addresses 300 to 396	R/W	Word	Same as relative addresses 300 to 396 Example (for status): Relative address 1108, obtained by adding 808 to relative address 300, will have the status of sensor Ch. 9.
41210 ~ 41310	1209 ~ 1309	4B9 ~ 51D	101	Sensor	10	Same item as relative addresses 300 to 396	R/W	Word	Same as relative addresses 300 to 396 Example (for status): Relative address 1209, obtained by adding 909 to relative address 300, will have the status of sensor Ch. 10.
41311 ~ 41411	1310 ~ 1410	51E ~ 582	101	Sensor	11	Same item as relative addresses 300 to 396	R/W	Word	Same as relative addresses 300 to 396 Example (for status): Relative address 1310, obtained by adding 1010 to relative address 300, will have the status of sensor Ch. 11.
41412 ~ 41512	1411 ~ 1511	583 ~ 5E7	101	Sensor	12	Same item as relative addresses 300 to 396	R/W	Word	Same as relative addresses 300 to 396 Example (for status): Relative address 1411, obtained by adding 1111 to relative address 300, will have the status of sensor Ch. 12.
41513 ~ 41613	1512 ~ 1612	5E8 ~ 64C	101	Sensor	13	Same item as relative addresses 300 to 396	R/W	Word	Same as relative addresses 300 to 396 Example (for status): Relative address 1512, obtained by adding 1212 to relative address 300, will have the status of sensor Ch. 13.
41614 ~ 41714	1613 ~ 1713	64D ~ 6B1	101	Sensor	14	Same item as relative addresses 300 to 396	R/W	Word	Same as relative addresses 300 to 396 Example (for status): Relative address 1613, obtained by adding 1313 to relative address 300, will have the status of sensor Ch. 14.
41715 ~ 41815	1714 ~ 1814	6B2 ~ 716	101	Sensor	15	Same item as relative addresses 300 to 396	R/W	Word	Same as relative addresses 300 to 396 Example (for status): Relative address 1714, obtained by adding 1414 to relative address 300, will have the status of sensor Ch. 15.
41816 ~ 41916	1815 ~ 1915	717 ~ 77B	101	Sensor	16	Same item as relative addresses 300 to 396	R/W	Word	Same as relative addresses 300 to 396 Example (for status): Relative address 1815, obtained by adding 1515 to relative address 300, will have the status of sensor Ch. 16.
42301	2300	8FC	4			Reservation	R	Char [8]	Reservation
42305	2304	900	4	Main		Serial No.	R	Char [8]	Same as relative address 261.
42309	2308	904	8	Sensor	1	Tag name (change notification)	R/W	Char [16]	It is read/write the tag name of the target sensor Ch. Refer to relative address 328 for data contents.
42317	2316	90C	8	Sensor	2				
42325	2324	914	8	Sensor	3				
42333	2332	91C	8	Sensor	4				
42341	2340	924	8	Sensor	5				
42349	2348	92C	8	Sensor	6				
42357	2356	934	8	Sensor	7				
42365	2364	93C	8	Sensor	8				
42373	2372	944	8	Sensor	9				
42381	2380	94C	8	Sensor	10				
42389	2388	954	8	Sensor	11				
42397	2396	95C	8	Sensor	12				
42405	2404	964	8	Sensor	13				
42413	2412	96C	8	Sensor	14				
42421	2420	974	8	Sensor	15				
42429	2428	97C	8	Sensor	16				
42437	2436	984	8	Sensor	1	Gas name (change notification)	R/W	Char [16]	It is read/write the gas name of the target sensor Ch. Refer to relative address 320 for data contents.
42445	2444	98C	8	Sensor	2				
42453	2452	994	8	Sensor	3				
42461	2460	99C	8	Sensor	4				



Register No.	Relative address		Words	Unit	Sensor Ch.	Register item	Access	Type	Data contents
	Dec	hex							
42469	2468	9A4	8	Sensor	5	Gas name (change notification)	R/W	Char [16]	It is read/write the gas name of the target sensor Ch. Refer to relative address 320 for data contents.
42477	2476	9AC	8	Sensor	6				
42485	2484	9B4	8	Sensor	7				
42493	2492	9BC	8	Sensor	8				
42501	2500	9C4	8	Sensor	9				
42509	2508	9CC	8	Sensor	10				
42517	2516	9D4	8	Sensor	11				
42525	2524	9DC	8	Sensor	12				
42533	2532	9E4	8	Sensor	13				
42541	2540	9EC	8	Sensor	14				
42549	2548	9F4	8	Sensor	15				
42557	2556	9FC	8	Sensor	16				
42565	2564	A04	1	Sensor	1				
42566	2565	A05	1	Sensor	2				
42567	2566	A06	1	Sensor	3				
42568	2567	A07	1	Sensor	4				
42569	2568	A08	1	Sensor	5				
42570	2569	A09	1	Sensor	6				
42571	2570	A0A	1	Sensor	7				
42572	2571	A0B	1	Sensor	8				
42573	2572	A0C	1	Sensor	9				
42574	2573	A0D	1	Sensor	10				
42575	2574	A0E	1	Sensor	11				
42576	2575	A0F	1	Sensor	12				
42577	2576	A10	1	Sensor	13				
42578	2577	A11	1	Sensor	14				
42579	2578	A12	1	Sensor	15				
42580	2579	A13	1	Sensor	16				
42581	2580	A14	1	Sensor	1	Decimal point (change notification)	R/W*	Word	It is read/write the decimal point position of the target sensor Ch.'s concentration (integer). *The writing is possible only when the unit allocation is the AI module. Refer to relative address 315 for data contents.
42582	2581	A15	1	Sensor	2				
42583	2582	A16	1	Sensor	3				
42584	2583	A17	1	Sensor	4				
42585	2584	A18	1	Sensor	5				
42586	2585	A19	1	Sensor	6				
42587	2586	A1A	1	Sensor	7				
42588	2587	A1B	1	Sensor	8				
42589	2588	A1C	1	Sensor	9				
42590	2589	A1D	1	Sensor	10				
42591	2590	A1E	1	Sensor	11				
42592	2591	A1F	1	Sensor	12				
42593	2592	A20	1	Sensor	13				
42594	2593	A21	1	Sensor	14				
42595	2594	A22	1	Sensor	15				
42596	2595	A23	1	Sensor	16				



Register No.	Relative address		Words	Unit	Sensor Ch.	Register item	Access	Type	Data contents
	Dec	hex							
42597	2596	A24	2	Sensor	1	Full scale (floating point) (change notification)	R/W*	Word	It is read/write the full scale value of the target sensor Ch. in floating point (IEEE754 single-precision). *The writing is possible only when the unit allocation is the AI module. Refer to relative address 316 for data contents.
42599	2598	A26	2	Sensor	2				
42601	2600	A28	2	Sensor	3				
42603	2602	A2A	2	Sensor	4				
42605	2604	A2C	2	Sensor	5				
42607	2606	A2E	2	Sensor	6				
42609	2608	A30	2	Sensor	7				
42611	2610	A32	2	Sensor	8				
42613	2612	A34	2	Sensor	9				
42615	2614	A36	2	Sensor	10				
42617	2616	A38	2	Sensor	11				
42619	2618	A3A	2	Sensor	12				
42621	2620	A3C	2	Sensor	13				
42623	2622	A3E	2	Sensor	14				
42625	2624	A40	2	Sensor	15				
42627	2626	A42	2	Sensor	16				
42629	2628	A44	1	Sensor	1	Unit (change notification)	R/W*	Word	It is read/write the unit code of the target sensor Ch. *The writing is possible only when the unit allocation is the AI module. Refer to relative address 318 for data contents.
42630	2629	A45	1	Sensor	2				
42631	2630	A46	1	Sensor	3				
42632	2631	A47	1	Sensor	4				
42633	2632	A48	1	Sensor	5				
42634	2633	A49	1	Sensor	6				
42635	2634	A4A	1	Sensor	7				
42636	2635	A4B	1	Sensor	8				
42637	2636	A4C	1	Sensor	9				
42638	2637	A4D	1	Sensor	10				
42639	2638	A4E	1	Sensor	11				
42640	2639	A4F	1	Sensor	12				
42641	2640	A50	1	Sensor	13				
42642	2641	A51	1	Sensor	14				
42643	2642	A52	1	Sensor	15				
42644	2643	A53	1	Sensor	16				
42645	2644	A54	1	Main		Reservation			Reservation
42646	2645	A55	1	Main		DO unit allocation	R	Word	Same as relative address 349.
42647	2646	A56	1	Main		4-20mA input use CH. information	R	Word	Same as relative address 350.
42648	2647	A57	1	Main		Reservation			Reservation

Register No.	Relative address		Words	Unit	Sensor Ch.	Register item	Access	Type	Data contents
	Dec	hex							
42649	2648	A58	1	Sensor	1	Alarm mode (change notification)	R	Word	It is read the alarm mode information of the target sensor Ch. Refer to relative address 319 for data contents.
42650	2649	A59	1	Sensor	2				
42651	2650	A5A	1	Sensor	3				
42652	2651	A5B	1	Sensor	4				
42653	2652	A5C	1	Sensor	5				
42654	2653	A5D	1	Sensor	6				
42655	2654	A5E	1	Sensor	7				
42656	2655	A5F	1	Sensor	8				
42657	2656	A60	1	Sensor	9				
42658	2657	A61	1	Sensor	10				
42659	2658	A62	1	Sensor	11				
42660	2659	A63	1	Sensor	12				
42661	2660	A64	1	Sensor	13				
42662	2661	A65	1	Sensor	14				
42663	2662	A66	1	Sensor	15				
42664	2663	A67	1	Sensor	16				
42665	2664	A68	2	Sensor	1	Fault simulation test mode (fault detail status)	R	Word	It is read the fault detail status of target sensor ch.'s fault simulation test mode. The bit contents of the fault detail status are the same as those of relative address 2.
42667	2666	A6A	2	Sensor	2				
42669	2668	A6C	2	Sensor	3				
42671	2670	A6E	2	Sensor	4				
42673	2672	A70	2	Sensor	5				
42675	2674	A72	2	Sensor	6				
42677	2676	A74	2	Sensor	7				
42679	2678	A76	2	Sensor	8				
42681	2680	A78	2	Sensor	9				
42683	2682	A7A	2	Sensor	10				
42685	2684	A7C	2	Sensor	11				
42687	2686	A7E	2	Sensor	12				
42689	2688	A80	2	Sensor	13				
42691	2690	A82	2	Sensor	14				
42693	2692	A84	2	Sensor	15				
42695	2694	A86	2	Sensor	16				
42697	2696	A88	2	Sensor	1	Fault simulation test mode (status)	R	Word	It is read the status of target sensor ch.'s fault simulation test mode. The bit contents of the status are the same as those of relative address 0.
42699	2698	A8A	2	Sensor	2				
42701	2700	A8C	2	Sensor	3				
42703	2702	A8E	2	Sensor	4				
42705	2704	A90	2	Sensor	5				
42707	2706	A92	2	Sensor	6				
42709	2708	A94	2	Sensor	7				
42711	2710	A96	2	Sensor	8				
42713	2712	A98	2	Sensor	9				
42715	2714	A9A	2	Sensor	10				
42717	2716	A9C	2	Sensor	11				
42719	2718	A9E	2	Sensor	12				
42721	2720	AA0	2	Sensor	13				
42723	2722	AA2	2	Sensor	14				
42725	2724	AA4	2	Sensor	15				
42727	2726	AA6	2	Sensor	16				

Register No.	Relative address		Words	Unit	Sensor Ch.	Register item	Access	Type	Data contents
	Dec	hex							
42729	2728	AA8	1	Sensor	1	Concentration (integer)	R	Word	It is read the gas concentration value (integer) of the target sensor Ch. Refer to relative address 4 for data contents.
42730	2729	AA9	1	Sensor	2				
42731	2730	AAA	1	Sensor	3				
42732	2731	AAB	1	Sensor	4				
42733	2732	AAC	1	Sensor	5				
42734	2733	AAD	1	Sensor	6				
42735	2734	AAE	1	Sensor	7				
42736	2735	AAF	1	Sensor	8				
42737	2736	AB0	1	Sensor	9				
42738	2737	AB1	1	Sensor	10				
42739	2738	AB2	1	Sensor	11				
42740	2739	AB3	1	Sensor	12				
42741	2740	AB4	1	Sensor	13				
42742	2741	AB5	1	Sensor	14				
42743	2742	AB6	1	Sensor	15				
42744	2743	AB7	1	Sensor	16				
42745	2744	AB8	1	Sensor	1	Alarm setting (AL1) (integer) (change notification)	R/W	Word	It is read/write the alarm setting (AL1) (integer) of the target sensor Ch. Refer to relative address 308 for data contents.
42746	2745	AB9	1	Sensor	2				
42747	2746	ABA	1	Sensor	3				
42748	2747	ABB	1	Sensor	4				
42749	2748	ABC	1	Sensor	5				
42750	2749	ABD	1	Sensor	6				
42751	2750	ABE	1	Sensor	7				
42752	2751	ABF	1	Sensor	8				
42753	2752	AC0	1	Sensor	9				
42754	2753	AC1	1	Sensor	10				
42755	2754	AC2	1	Sensor	11				
42756	2755	AC3	1	Sensor	12				
42757	2756	AC4	1	Sensor	13				
42758	2757	AC5	1	Sensor	14				
42759	2758	AC6	1	Sensor	15				
42760	2759	AC7	1	Sensor	16				
42761	2760	AC8	1	Sensor	1	Alarm setting (AL2) (integer) (change notification)	R/W	Word	It is read/write the alarm setting (AL2) (integer) of the target sensor Ch. Refer to relative address 309 for data contents.
42762	2761	AC9	1	Sensor	2				
42763	2762	ACA	1	Sensor	3				
42764	2763	ACB	1	Sensor	4				
42765	2764	ACC	1	Sensor	5				
42766	2765	ACD	1	Sensor	6				
42767	2766	ACE	1	Sensor	7				
42768	2767	ACF	1	Sensor	8				
42769	2768	AD0	1	Sensor	9				
42770	2769	AD1	1	Sensor	10				
42771	2770	AD2	1	Sensor	11				
42772	2771	AD3	1	Sensor	12				
42773	2772	AD4	1	Sensor	13				
42774	2773	AD5	1	Sensor	14				
42775	2774	AD6	1	Sensor	15				
42776	2775	AD7	1	Sensor	16				
42777	2776	AD8	2	Sensor	1	Concentration (floating point)	R	Word	It is read the gas concentration value (floating point) of the target sensor Ch. Refer to relative address 129 for data contents.
42779	2778	ADA	2	Sensor	2				
42781	2780	ADC	2	Sensor	3				
42783	2782	ADE	2	Sensor	4				
42785	2784	AE0	2	Sensor	5				
42787	2786	AE2	2	Sensor	6				
42789	2788	AE4	2	Sensor	7				
42791	2790	AE6	2	Sensor	8				

Register No.	Relative address		Words	Unit	Sensor Ch.	Register item	Access	Type	Data contents
	Dec	hex							
42793	2792	AE8	2	Sensor	9	Concentration (floating point)	R	Word	It is read the gas concentration value (floating point) of the target sensor Ch. Refer to relative address 129 for data contents.
42795	2794	AEA	2	Sensor	10				
42797	2796	AEC	2	Sensor	11				
42799	2798	AEE	2	Sensor	12				
42801	2800	AF0	2	Sensor	13				
42803	2802	AF2	2	Sensor	14				
42805	2804	AF4	2	Sensor	15				
42807	2806	AF6	2	Sensor	16				
42809	2808	AF8	2	Sensor	1				
42811	2810	AFA	2	Sensor	2				
42813	2812	AFC	2	Sensor	3				
42815	2814	AFE	2	Sensor	4				
42817	2816	B00	2	Sensor	5				
42819	2818	B02	2	Sensor	6				
42821	2820	B04	2	Sensor	7				
42823	2822	B06	2	Sensor	8				
42825	2824	B08	2	Sensor	9				
42827	2826	B0A	2	Sensor	10				
42829	2828	B0C	2	Sensor	11				
42831	2830	B0E	2	Sensor	12				
42833	2832	B10	2	Sensor	13				
42835	2834	B12	2	Sensor	14				
42837	2836	B14	2	Sensor	15				
42839	2838	B16	2	Sensor	16				

Register No.	Relative address		Words	Unit	Sensor Ch.	Register item	Access	Type	Data contents
	Dec	hex							
42841	2840	B18	2	Sensor	1	Alarm setting (AL2) (floating point) (change notification)	R/W	Word	It is read/write the alarm setting (AL2) (floating point) of the target sensor Ch. Refer to relative address 312 for data contents.
42843	2842	B1A	2	Sensor	2				
42845	2844	B1C	2	Sensor	3				
42847	2846	B1E	2	Sensor	4				
42849	2848	B20	2	Sensor	5				
42851	2850	B22	2	Sensor	6				
42853	2852	B24	2	Sensor	7				
42855	2854	B26	2	Sensor	8				
42857	2856	B28	2	Sensor	9				
42859	2858	B2A	2	Sensor	10				
42861	2860	B2C	2	Sensor	11				
42863	2862	B2E	2	Sensor	12				
42865	2864	B30	2	Sensor	13				
42867	2866	B32	2	Sensor	14				
42869	2868	B34	2	Sensor	15				
42871	2870	B36	2	Sensor	16				

Register No.	Relative address		Words	Unit	Sensor Ch.	Register item	Access	Type	Data contents
	Dec	hex							
42873	2872	B38	1	Sensor	1	Maint mode setting	R/W	Word	It is read/write the maintenance mode settings of the target sensor Ch. Refer to relative address 389 for data contents.
42874	2873	B39	1	Sensor	2				
42875	2874	B3A	1	Sensor	3				
42876	2875	B3B	1	Sensor	4				
42877	2876	B3C	1	Sensor	5				
42878	2877	B3D	1	Sensor	6				
42879	2878	B3E	1	Sensor	7				
42880	2879	B3F	1	Sensor	8				
42881	2880	B40	1	Sensor	9				
42882	2881	B41	1	Sensor	10				
42883	2882	B42	1	Sensor	11				
42884	2883	B43	1	Sensor	12				
42885	2884	B44	1	Sensor	13				
42886	2885	B45	1	Sensor	14				
42887	2886	B46	1	Sensor	15				
42888	2887	B47	1	Sensor	16				
42889	2888	B48	1	Sensor	1	Alarm tests shift ON/OFF	R/W	Word	It is read/write the alarm test shift ON/OFF of the target sensor Ch. Refer to relative address 390 for data contents.
42890	2889	B49	1	Sensor	2				
42891	2890	B4A	1	Sensor	3				
42892	2891	B4B	1	Sensor	4				
42893	2892	B4C	1	Sensor	5				
42894	2893	B4D	1	Sensor	6				
42895	2894	B4E	1	Sensor	7				
42896	2895	B4F	1	Sensor	8				
42897	2896	B50	1	Sensor	9				
42898	2897	B51	1	Sensor	10				
42899	2898	B52	1	Sensor	11				
42900	2899	B53	1	Sensor	12				
42901	2900	B54	1	Sensor	13				
42902	2901	B55	1	Sensor	14				
42903	2902	B56	1	Sensor	15				
42904	2903	B57	1	Sensor	16				
42905	2904	B58	1	Sensor	1	Alarm test mode (integer)	R/W	Word	It is read/write the alarm test mode (integer) of the target sensor Ch. Refer to relative address 391 for data contents.
42906	2905	B59	1	Sensor	2				
42907	2906	B5A	1	Sensor	3				
42908	2907	B5B	1	Sensor	4				
42909	2908	B5C	1	Sensor	5				
42910	2909	B5D	1	Sensor	6				
42911	2910	B5E	1	Sensor	7				
42912	2911	B5F	1	Sensor	8				
42913	2912	B60	1	Sensor	9				
42914	2913	B61	1	Sensor	10				
42915	2914	B62	1	Sensor	11				
42916	2915	B63	1	Sensor	12				
42917	2916	B64	1	Sensor	13				
42918	2917	B65	1	Sensor	14				
42919	2918	B66	1	Sensor	15				
42920	2919	B67	1	Sensor	16				
42921	2920	B68	2	Sensor	1	Alarm test mode (floating point)	R/W	Word	It is read/write the alarm test mode (floating point) of the target sensor Ch. Refer to relative address 392 for data contents.
42923	2922	B6A	2	Sensor	2				
42925	2924	B6C	2	Sensor	3				
42927	2926	B6E	2	Sensor	4				
42929	2928	B70	2	Sensor	5				
42931	2930	B72	2	Sensor	6				
42933	2932	B74	2	Sensor	7				

Register No.	Relative address		Words	Unit	Sensor Ch.	Register item	Access	Type	Data contents
	Dec	hex							
42935	2934	B76	2	Sensor	8	Alarm test mode (floating point)	R/W	Word	It is read/write the alarm test mode (floating point) of the target sensor Ch. Refer to relative address 392 for data contents.
42937	2936	B78	2	Sensor	9				
42939	2938	B7A	2	Sensor	10				
42941	2940	B7C	2	Sensor	11				
42943	2942	B7E	2	Sensor	12				
42945	2944	B80	2	Sensor	13				
42947	2946	B82	2	Sensor	14				
42949	2948	B84	2	Sensor	15				
42951	2950	B86	2	Sensor	16				
42953	2952	B88	1	Sensor	1	Alarm delay time (AL1) (change notification)	R/W	Word	It is read/write the alarm delay time (AL1) of the target sensor Ch. Refer to relative address 336 for data contents.
42954	2953	B89	1	Sensor	2				
42955	2954	B8A	1	Sensor	3				
42956	2955	B8B	1	Sensor	4				
42957	2956	B8C	1	Sensor	5				
42958	2957	B8D	1	Sensor	6				
42959	2958	B8E	1	Sensor	7				
42960	2959	B8F	1	Sensor	8				
42961	2960	B90	1	Sensor	9				
42962	2961	B91	1	Sensor	10				
42963	2962	B92	1	Sensor	11				
42964	2963	B93	1	Sensor	12				
42965	2964	B94	1	Sensor	13				
42966	2965	B95	1	Sensor	14				
42967	2966	B96	1	Sensor	15				
42968	2967	B97	1	Sensor	16				
42969	2968	B98	1	Sensor	1	Alarm delay time (AL2) (change notification)	R/W	Word	It is read/write the alarm delay time (AL2) of the target sensor Ch. Refer to relative address 337 for data contents.
42970	2969	B99	1	Sensor	2				
42971	2970	B9A	1	Sensor	3				
42972	2971	B9B	1	Sensor	4				
42973	2972	B9C	1	Sensor	5				
42974	2973	B9D	1	Sensor	6				
42975	2974	B9E	1	Sensor	7				
42976	2975	B9F	1	Sensor	8				
42977	2976	BA0	1	Sensor	9				
42978	2977	BA1	1	Sensor	10				
42979	2978	BA2	1	Sensor	11				
42980	2979	BA3	1	Sensor	12				
42981	2980	BA4	1	Sensor	13				
42982	2981	BA5	1	Sensor	14				
42983	2982	BA6	1	Sensor	15				
42984	2983	BA7	1	Sensor	16				

# 7 Device Status Information

This section explains the device status information in each operating mode during gas alarm, fault alarm, test mode, and maintenance mode.

## 7.1 Explanation of Operation at Gas Alarm

When the detected gas concentration value exceeds each alarm setting value, each alarm contact operates after the alarm delay time, and this product enters the gas alarm state.

The master can detect the gas alarm by reading the status information in register No. 40001 (for sensor 1) of the Modbus communication.

When the detected gas concentration value drops below the respective alarm setting value, the unit automatically resets to the gas alarm state.

**NOTE**

- For description of the main unit's operation during the gas alarm, refer to "7.1 Gas Alarm Operation" in "PS-8 Series Instruction Manual for Operation".

Register No. 40001 (for sensor 1) status information data is double-word size and consists of the upper word (lower register number) and the lower word (higher register number).

Gas alarm 1 (Alarm 1) is located in bit 0 of the upper word and gas alarm 2 (Alarm 2) in bit 1 of the lower word.

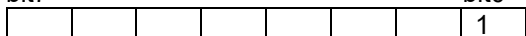
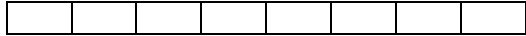
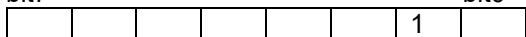
Alarm type	Register item	Register No.	Data contents
Gas alarm (Alarm 1)	Current value (status information)	40001	0: without alarm / 1: with alarm Upper word Bit16 <span style="float:right">bit8</span>  bit7 <span style="float:right">bit0</span>  Bit0: Alarm 1
Gas alarm (Alarm 2)			0: without alarm / 1: with alarm Upper word Bit16 <span style="float:right">bit8</span>  bit7 <span style="float:right">bit0</span>  Bit1: Alarm 2



## 7.2 Explanation of Operation at Trouble Alarm

The master can detect the following trouble alarms by reading the register No. 40001 (for sensor 1) status information data in Modbus communication.

The trouble alarms are automatically reset when the symptoms are recovered.

During a trouble alarm (with the exception of abnormalities in continued operation), the trouble will be prioritized over the alarm. However, when abnormalities in continued operation occur, the alarm will be prioritized.

### NOTE

- For description of the main unit's operation during the trouble alarm, refer to "7.2 Fault Alarm Operation" in "PS-8 Series Instruction Manual for Operation".
- For description of the main unit's LCD screen, refer to "4.1.4 LCD" in "PS-8 Series Instruction Manual for Operation".

#### (1) Flow rate decrease fault

When not flowing at the specified flow rate.

#### (2) Sensor related collective fault

When sensor unit EEPROM failure, sensor type mismatch or sensor failure occurs in the sensor unit.

#### (3) Fan failure

When fan rotation has stopped

#### (4) Device failure

When internal failure of the device occurs

#### (5) Interunit communication failure

When communication with the connected unit is lost

#### (6) Collectively failure

When any of the failures in (2) to (5) occur

#### (7) Abnormalities in continued operation

When abnormalities in continued operation occur. The Operation Continuation Abnormality is turned ON when one of Bit 16 Time Synchronisation Abnormality, Bit 17 Mail Transmission Abnormality, Bit 19 Date and Time Setting Abnormality or Bit 20 NAND FLASH Abnormality occurs in the Fault Detail Status.

Register No. 40001 (for sensor 1) status information data is double-word size and consists of the upper word (lower register number) and the lower word (higher register number).

Trouble alarms are located in the upper word and lower word. The following table shows each trouble alarm.

Trouble alarm type	Register item	Register No.	Data contents
Flow rate decrease	Current value (status information)	40001 (for sensor 1)	0: Normal / 1: Abnormal Upper word Bit15 <span style="float: right;">bit8</span> <div style="border: 1px solid black; width: 100%; height: 15px; margin: 5px 0;"></div> bit7 <span style="float: right;">bit0</span> <div style="border: 1px solid black; width: 100%; height: 15px; margin: 5px 0; text-align: center;">1</div> Bit3: Low flow failure
Sensor related collective fault			0: Normal / 1: Abnormal Upper word Bit15 <span style="float: right;">bit8</span> <div style="border: 1px solid black; width: 100%; height: 15px; margin: 5px 0;"></div> bit7 <span style="float: right;">bit0</span> <div style="border: 1px solid black; width: 100%; height: 15px; margin: 5px 0; text-align: center;">1</div> Bit4: Sensor related collective fault
Fan failure			0: Normal / 1: Abnormal Upper word Bit15 <span style="float: right;">bit8</span> <div style="border: 1px solid black; width: 100%; height: 15px; margin: 5px 0;"></div> bit7 <span style="float: right;">bit0</span> <div style="border: 1px solid black; width: 100%; height: 15px; margin: 5px 0; text-align: center;">1</div> Bit5: Fan failure
Device failure			0: Normal / 1: Abnormal Upper word Bit15 <span style="float: right;">bit8</span> <div style="border: 1px solid black; width: 100%; height: 15px; margin: 5px 0;"></div> bit7 <span style="float: right;">bit0</span> <div style="border: 1px solid black; width: 100%; height: 15px; margin: 5px 0; text-align: center;">1</div> Bit6: Device failure
Interunit comm. failure			0: Normal / 1: Abnormal Upper word Bit15 <span style="float: right;">bit8</span> <div style="border: 1px solid black; width: 100%; height: 15px; margin: 5px 0;"></div> bit7 <span style="float: right;">bit0</span> <div style="border: 1px solid black; width: 100%; height: 15px; margin: 5px 0; text-align: center;">1</div> Bit7: Interunit comm. failure

Trouble alarm type	Register item	Register No.	Data contents
Collectively failure			0: Normal / 1: Abnormal Lower word Bit31(Bit15) <span style="float:right">Bit24(Bitbit8)</span> <div style="border: 1px solid black; width: 100%; height: 15px; margin: 2px 0;"></div> Bit23(bit7) <span style="float:right">Bit16(bit0)</span> <div style="border: 1px solid black; width: 100%; height: 15px; margin: 2px 0;"></div> Bit21(Bit5): Collectively failure
Abnormalities in continued operation			0: Normal / 1: Abnormal Lower word Bit31(Bit15) <span style="float:right">Bit24(Bitbit8)</span> <div style="border: 1px solid black; width: 100%; height: 15px; margin: 2px 0;"></div> Bit23(bit7) <span style="float:right">Bit16(bit0)</span> <div style="border: 1px solid black; width: 100%; height: 15px; margin: 2px 0;"></div> Bit18(Bit2): Abnormalities in continued operation

### 7.3 Explanation of Test Mode Settings and Operation

This product enters the test mode by setting alarm tests in the menu.

This product enters the test mode when the alarm test shift ON/OFF register is set to alarm test start (ON) by the master (host device) via Modbus communication. Alarm cancellation is performed by setting alarm test end (OFF).

When the test mode is entered, "TEST" is displayed on the LCD of this product.

The test mode is automatically cancelled after 10 minutes.

#### NOTE

- For setting of the main unit's test mode, refer to "10.8 Alarm Test" in "PS-8 Series Instruction Manual for Communication".

The following table shows the setting registers for the test mode of Modbus communication.

Register item	Register No.	Data type	Data contents
Alarm test shift ON/OFF	40391 (for sensor 1)	Word	Alarm test start (ON) / Alarm test end (OFF) OFF: 0x0000 / ON: 0x0001
Alarm test mode	40392 (for sensor 1)	Word	Test concentration setting Example of written data: In the case of FS. 25.0, full scale 250, fixed decimal point 1. If the alarm test value is written at 50, the test value is 5.0.
Alarm test mode (floating point)	40393 (for sensor 1)	Dword	Test concentration setting Example of written data: In the case of 25.3, 0x41CA6666(hex) Upper word : 0x6666(hex) Lower word : 0x41CA(hex)

The master can check the status of the test mode by reading the register number No. 40001 (for sensor 1) status information in Modbus communication.

Register No. 40001 (for sensor 1) status information data is double-word size and consists of the upper word (lower register number) and the lower word (higher register number).

The test mode is located in bit15 of the upper word. As shown in the table below.

	Register item	Register No.	Data contents
Test mode	Current value (status information)	40001 (for sensor 1)	0 : OFF / 1 : ON Upper word Bit15 <span style="float:right">bit8</span> <div style="border: 1px solid black; width: 100%; height: 15px; display: flex; justify-content: space-between; align-items: center;"> <span>1</span> <span></span> <span></span> <span></span> <span></span> <span></span> <span></span> <span></span> </div> bit7 <span style="float:right">bit0</span> <div style="border: 1px solid black; width: 100%; height: 15px; display: flex; justify-content: space-between; align-items: center;"> <span></span> <span></span> <span></span> <span></span> <span></span> <span></span> <span></span> <span></span> </div> Bit5: Alarm tests

**CAUTION**

- You cannot perform the gas alarm test during warm-up.
- In the alarm test, the external contacts are activated. Before performing various operations, set the maintenance mode or unlock the external device interlock as necessary.
- The test status is canceled in approximately 10 minutes from the start of the gas alarm test. If no operation continues for approximately 10 minutes, the display automatically shifts to the concentration screen.
- If either channel is in gas alarm or fault simulation test is in progress, the alarm cannot be tested.
- If the fault alarm occurs on the channel under test during the alarm test, the alarm test is automatically canceled.
- If the gas alarm occurs during the gas alarm test, the gas alarm test is not automatically canceled.
- If the power turns OFF during the gas alarm test, the gas alarm test will be canceled at the next startup.

## 7.4 Explanation of Maintenance Mode Settings and Operation

This product can be switched to the maintenance mode by setting the maintenance mode in the menu. There are two maintenance modes for this product: Maintenance Mode 1 and Maintenance Mode 2. In addition, it is possible to distinguish whether the setting is made by external operation or by device operation.

### NOTE

- For the setting and operation description of Maintenance Mode 1 and Maintenance Mode 2, refer to "8 Maintenance Mode" in the "PS-8 Series Instruction Manual for Operation".

When 1 is set to the maintenance mode setting register via Modbus communication from the master (host device), maintenance mode 1 is selected. When 2 is set to the setting register, maintenance mode 2 is selected. Setting 0 to the setting register cancels the maintenance mode.

When the maintenance mode is entered, the maintenance mode icon is displayed on the LCD of this product.

The maintenance mode is automatically cancelled after 12 hours.

During maintenance mode, bit0 to bit10 and bit18 to bit21 of the status information are masked to 0.

As the concentration information during Maintenance Mode 1, the gas concentration is output.

The concentration information during Maintenance Mode 2 is fixed to the base value.

The following table shows the setting registers for the maintenance mode of Modbus communication.

Register item	Register No.	Data type	Data contents
Maintenance mode	40390 (for sensor 1)	Word	OFF: 0x0000 Maintenance mode 1: 0x0001 Maintenance mode 2: 0x0002

The master can check the status of the maintenance mode by reading the register number No. 40001 (for sensor 1) status information in Modbus communication.

Register No. 40001 (for sensor 1) status information data is double-word size and consists of the upper word (lower register number) and the lower word (higher register number).

The maintenance mode is located in bit14, 13, 12, and 11 of the upper word. As shown in the table below.

Register item	Register No.	Data contents	Gas alarm contact	Trouble alarm contact																								
Maintenance mode 1 (when setting by external operation including Modbus)	40001 (for sensor 1)	0 : OFF / 1 : ON Upper word Bit15 <span style="float:right">bit8</span> <table border="1" style="width:100%; text-align:center;"> <tr> <td style="width:25%;"></td> <td style="width:25%;"></td> <td style="width:25%;"></td> <td style="width:25%;"></td> <td style="width:25%;"></td> <td style="width:25%;"></td> <td style="width:25%;"></td> <td style="width:25%;"></td> </tr> <tr> <td></td> <td>1</td> <td></td> <td></td> <td></td> <td></td> <td></td> <td></td> </tr> </table> bit7 <span style="float:right">bit0</span> <table border="1" style="width:100%; text-align:center;"> <tr> <td style="width:25%;"></td> <td style="width:25%;"></td> <td style="width:25%;"></td> <td style="width:25%;"></td> <td style="width:25%;"></td> <td style="width:25%;"></td> <td style="width:25%;"></td> <td style="width:25%;"></td> </tr> </table> Bit13: Maintenance mode 1										1															Not operating	Not operating
	1																											
Maintenance mode 2 (when setting by external operation including Modbus)	0 : OFF / 1 : ON Upper word Bit15 <span style="float:right">bit8</span> <table border="1" style="width:100%; text-align:center;"> <tr> <td style="width:25%;"></td> <td style="width:25%;"></td> <td style="width:25%;"></td> <td style="width:25%;"></td> <td style="width:25%;"></td> <td style="width:25%;"></td> <td style="width:25%;"></td> <td style="width:25%;"></td> </tr> <tr> <td></td> <td>1</td> <td></td> <td></td> <td></td> <td></td> <td></td> <td></td> </tr> </table> bit7 <span style="float:right">bit0</span> <table border="1" style="width:100%; text-align:center;"> <tr> <td style="width:25%;"></td> <td style="width:25%;"></td> <td style="width:25%;"></td> <td style="width:25%;"></td> <td style="width:25%;"></td> <td style="width:25%;"></td> <td style="width:25%;"></td> <td style="width:25%;"></td> </tr> </table> Bit14: Maintenance mode 2										1															Not operating	Not operating	
	1																											

Register item		Register No.	Data contents	Gas alarm contact	Trouble alarm contact																																
Maintenance mode 1 (when setting by device operation)	Current value (status information)	40001 (for sensor 1)	0 : OFF / 1 : ON Upper word Bit15 <span style="float:right">bit8</span> <table border="1" style="width:100%; text-align:center; border-collapse: collapse;"> <tr> <td style="width:12.5%;"></td><td style="width:12.5%;"></td><td style="width:12.5%;"></td><td style="width:12.5%;"></td><td style="width:12.5%;"></td><td style="width:12.5%;"></td><td style="width:12.5%;"></td><td style="width:12.5%;"></td> </tr> <tr> <td></td><td></td><td></td><td>1</td><td></td><td></td><td></td><td></td> </tr> </table> bit7 <span style="float:right">bit0</span> <table border="1" style="width:100%; text-align:center; border-collapse: collapse;"> <tr> <td style="width:12.5%;"></td><td style="width:12.5%;"></td><td style="width:12.5%;"></td><td style="width:12.5%;"></td><td style="width:12.5%;"></td><td style="width:12.5%;"></td><td style="width:12.5%;"></td><td style="width:12.5%;"></td> </tr> <tr> <td></td><td></td><td></td><td></td><td></td><td></td><td></td><td></td> </tr> </table> Bit11: Maintenance mode 1												1																					Not operating	Not operating
			1																																		
Maintenance mode 2 (when setting by device operation)			0 : OFF / 1 : ON Upper word Bit15 <span style="float:right">bit8</span> <table border="1" style="width:100%; text-align:center; border-collapse: collapse;"> <tr> <td style="width:12.5%;"></td><td style="width:12.5%;"></td><td style="width:12.5%;"></td><td style="width:12.5%;"></td><td style="width:12.5%;"></td><td style="width:12.5%;"></td><td style="width:12.5%;"></td><td style="width:12.5%;"></td> </tr> <tr> <td></td><td></td><td></td><td>1</td><td></td><td></td><td></td><td></td> </tr> </table> bit7 <span style="float:right">bit0</span> <table border="1" style="width:100%; text-align:center; border-collapse: collapse;"> <tr> <td style="width:12.5%;"></td><td style="width:12.5%;"></td><td style="width:12.5%;"></td><td style="width:12.5%;"></td><td style="width:12.5%;"></td><td style="width:12.5%;"></td><td style="width:12.5%;"></td><td style="width:12.5%;"></td> </tr> <tr> <td></td><td></td><td></td><td></td><td></td><td></td><td></td><td></td> </tr> </table> Bit12: Maintenance mode 2												1																					Not operating	Not operating
			1																																		

<b>WARNING</b>	
	<ul style="list-style-type: none"> <li>• Be sure to check that the unit is set to normal mode during normal use (gas concentration monitoring). If the unit is used with the setting set to maintenance mode 1 or 2, the gas alarm contact and trouble alarm contact will not operate. However, the alarm and fault status are displayed.</li> <li>• When in maintenance mode 2, the analog output will not change from 4 mA or 17.4 mA or 10.7 mA.</li> </ul>

<b>CAUTION</b>	
	<ul style="list-style-type: none"> <li>• Each maintenance mode will be automatically cancelled in approximately 12 hours.</li> <li>• When each maintenance mode is reset, the time up to automatic cancellation is reset to 12 hours.</li> <li>• Each maintenance mode remains in maintenance mode even after restart. However, the automatic cancellation time will be reset.</li> </ul>

**NOTE** • For the specifications of the main unit's gas alarm contact and trouble alarm contact, refer to "14 Specifications" in the "PS-8 Series Instruction Manual for Operation".

## 8 Before Assuming Malfunction

Before requesting a repair, please refer to the table below. If the product does not return to normal operation after performing the corresponding steps in the table or if your issue is not found in the table, consult New Cosmos or its authorized representative.

If the product goes into any unintended mode during adjustment or setting, cease the use of the product and consult with your supervisor.

### Communication

Problem/Error Message	Probable Cause	Solution/Reference
Modbus TCP (Ethernet) communication is not possible	LAN cable wiring is incorrect.	Connect the LAN cable. Check the wiring and reconnect the cable. "4 Connection Specifications"
	Poor LAN cable connection.	
	All devices related to communication are not powered on.	Check if that the power is on for this product and for the device that will be communicating externally, and then power it on. "2 System Configuration"
	Communication mode setting is incorrect.	Check if the communication mode setting is set to "TCP/IP". "5.1 Communication Mode Setting"
	The number of connected units or transmission distance exceeds the range of specifications.	Check the number of connected units and transmission distance to confirm that they are within the specification range, and reconnect them. "4 Connection Specifications"
Received data is incorrect.	Communication conditions are incorrect.	Check the IP address, subnet mask, and default gateway, and reconnect. "5.2.2 IP Address Setting"
		Check if the proxy server setting is turned OFF. "5.2.3 Network Environment Setting"
Received data is incorrect.	Function code is incorrect.	Check the function code. "6.2 Function Codes"
	Register address is incorrect.	Check that the register number is the correct register number for the data being received. "6.2 Function Codes"

## 9 Glossary

Term	Definition
Gas detector (or gas detector head)	Device used to detect the presence of a target gas and to give its concentration in the form of an electrical signal.
LEL	The lowest concentration at which an explosion occurs due to ignition when combustible gas and air are mixed. An abbreviation of "Lower Explosion Limit".
Explosion-proof structure	Structure applied to electrical devices to prevent them from becoming an ignition source and igniting the surrounding explosive atmosphere.
Maintenance and inspection	Tasks performed to ensure that equipment operates normally and correctly.





### Revision History

Document No.	Date	Revision
GAE-180-00	December 2024	00 (Initial issue)

Additional copies of this instruction manual may be purchased. Contact New Cosmos or its authorized representative for ordering.

**Authorized representative:**

**Manufacturer:**

NEW COSMOS ELECTRIC CO., LTD.  
2-5-4 Mitsuya-naka, Yodogawa-ku,  
Osaka 532-0036, Japan  
[www.newcosmos-global.com](http://www.newcosmos-global.com)

**NEW COSMOS ELECTRIC CO., LTD.**

---